

HR

EN

UPUTE ZA UPORABU

USER MANUAL

INDUKCIJSKO STAKLOKERAMIČKO UGRADBENO KUHALO

INDUCTION VITROCERAMIC BUILT-IN HOB

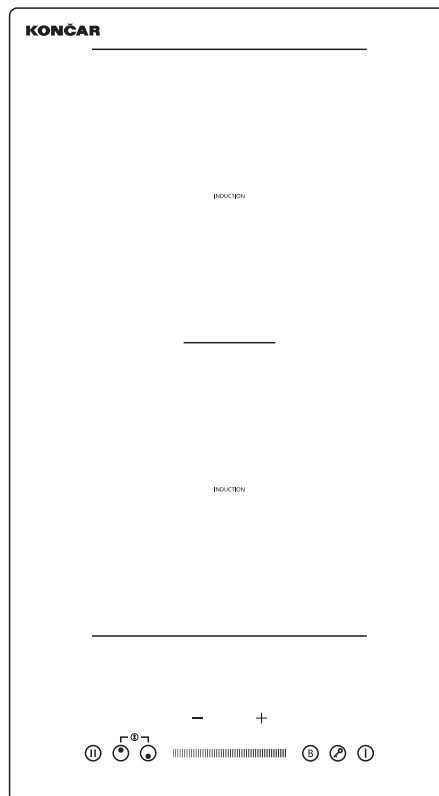

UK302INDM

KONČAR

UPUTE ZA UPORABU

ŠTOVANI KUPCI,

zahvaljujemo Vam na povjerenju koje ste nam ukazali kupnjom našeg proizvoda.



Za vaše lakše snalaženje pri uporabi proizvoda pripremili smo ove upute za uporabu.

Molimo vas da ih pomno pročitate jer ćete tako izbjeći greške, povećati uporabno trajanje proizvoda, štedjeti energiju i novac.

Upute su dostupne na web adresi: www.koncar-ka.hr

Upute za uporabu odložite na sigurno mjesto kako bi ih mogli koristiti i za buduće potrebe. Ako aparat prodate ili ustupite drugom vlasniku tada uz aparat priložite i ove upute.

		<p>POZOR! VRUĆA POVRŠINA!</p> <p>POZOR! OPASNOST OD POŽARA!</p>
	<p>POZOR! Elektromagnetsko polje na indukcijskoj zoni. Razni metalni predmeti (to ne vrijedi za specijalno posuđe namijenjeno za indukcijsko kuhalo) i elektroničke naprave ne smiju biti izloženi na području djelovanja.</p>	
	<p>POZOR! Osobama s ugrađenim srčanim stimulatorom preporučuje se konzultacija s liječnikom. Isto vrijedi za osobe s ugrađenim metalnim ili elektroničkim implantatima.</p>	

	<p>ZAŠTITA OKOLIŠA</p> <p>Ambalaža je izrađena tako da ne ugrožava okoliš; ambalažni materijal je ekološki i može se preraditi, odnosno reciklirati. Recikliranjem ambalaže štedi se na sirovinama i smanjuje količina industrijskog i kućanskog otpada.</p> <p>Sukladno Direktivi o otpadnoj električnoj i elektroničkoj opremi (WEEE) Europske unije, otpadna električna i elektronička oprema treba se odvojeno sakupljati i zbrinjavati. Simbol s lijeve strane znači da se električni i elektronički aparati na kraju njihova uporabnog vijeka ne smiju odbacivati zajedno s ostalim kućnim otpadom. Molimo da ovaj aparat predate lokalnoj tvrtki koja se bavi zbrinjavanjem otpada ili ga odnosi u reciklažno dvorište.</p> <p>Korisnik ne smije rastavljati aparat ili ostale komponente. Taj posao obavlja ovlaštena tvrtka koja se bavi recikliranjem takve vrste otpada.</p>
--	---

CE Aparati su ispitani i certificirani prema postojećim europskim normama za kućanske aparate. Ovaj proizvod je u skladu s EU normama.

	<p>Ovaj aparat je namijenjen isključivo za uporabu u domaćinstvu i nije namijenjen uporabi u profesionalne (komercijalne) svrhe ili namjene koje nadilaze uobičajenu uporabu u domaćinstvu. Ako se aparat ipak tako upotrebljava, tada proizvođač ne snosi nikakvu odgovornost, a jamstvo ne vrijedi.</p> <p>Proizvođač ne snosi nikakvu odgovornost za ozljede ili oštećenja izazvana nepravilnim postavljanjem ili uporabom te ne priznaje pravo na jamstvo u slučaju ne pridržavanja gore navedenih uputa.</p> <p>Proizvođač zadržava pravo promijeniti konstrukciju, mjere i težinu ako to smatra potrebnim radi poboljšanja kvalitete proizvoda, bez ugrožavanja osnovnih svojstava proizvoda.</p>
---	--

	<p>KVAROVI I REKLAMACIJE</p> <p>KVAROVE NEMOJTE POPRAVLJATI SAMI ! KVAR ODMAH prijavite na jedno od servisnih mjesta jer u suprotnom može doći do većeg oštećenja aparata, za što proizvođač neće preuzeti odgovornost.</p> <p>Ako do nekog kvara na aparatu dođe tijekom jamstvene dobi, nemojte ga popravljati sami. Reklamaciju ODMAH prijavite na jedno od servisnih mjesta jer u suprotnom može doći do većeg oštećenja aparata, za što proizvođač neće preuzeti odgovornost. Pri podnošenju reklamacije držite se teksta Jamstvenog lista.</p> <p>Najnovije informacije o servisnim mjestima nalaze se na web stranici www.koncar-ka.hr</p> <p>Bez predaje pravilno popunjenog Jamstvenog lista i priloženog računa za kupljeni aparat reklamacija je nevažeća.</p>
---	--

VAŽNA UPOZORENJA ZA SIGURNU UPORABU KUHALA!

NE RABITE APARAT PRIJE NEGO PROČITATE UPUTE ZA UPORABU I UPOZNATE SE S NJEGOVOM UPORABOM.

Zbog Vaše sigurnosti, morate se pridržavati naputaka u ovim uputama te na taj način smanjiti rizike od požara, eksplozija, električnog udara, oštećenja imovine, opasnosti po okoliš, ozljedama osoba s ozbiljnim ili tragičnim posljedicama.

Provjerite da li ste aparat primili neoštećen. U Slučaju oštećenja aparata, nastala tijekom transporta prijavite odmah prodavaču.
NE RABITE OŠTEĆENI APARAT.

POZORNOST! Proizvođač/distributer ne preuzima nikakvu odgovornost za oštećenja nastala prilikom uporabe neuzemljenog aparata, te u svezi bilo kakvog oštećenja i povreda ako se ne pridržava uputa za uporabu, u slučaju nesavjesne i nepravilne uporabe aparata, samostalnih popravaka i modifikacija te uporabe dijelova koji nisu originalni i odobreni od proizvođača.

POZORNOST! Po primitku aparata, raspakirajte ga, ambalažni materijal (plastičnu foliju, stiropor, drvo...) uklonite izvan domašaja djece kako se djeca ne bi ozljedila (progutala manje komade ili se ugušila plastičnom folijom).

POZORNOST! Ambalažni materijal (plastična folija, stiropor, drvo...) je opasan za djecu. Djeci nemojte dozvoliti igranje ambalažnim materijalom, kako ne bi progutala manje komade ili se ugušila plastičnom folijom.

POZORNOST! Ovaj aparat mogu upotrebljavati djeca u dobi od osam godina i starija te osobe sa smanjenim tjelesnim, osjetnim ili duševnim sposobnostima ili pomanjkanjem iskustva i znanja ako dobiju nadzor ili uputu o uporabi aparata na siguran način te razumiju uključene opasnosti.

POZORNOST! Ne ostavljajte djecu bez stalnog nadzora u blizini aparata.

POZORNOST! Djeca se ne smiju igrati aparatom, penjati, stajati ili sjediti na istom.

POZORNOST! Čišćenje i korisničko održavanje ne smiju obavljati djeca bez nadzora. Isto vrijedi i za maloljetne osobe.

POZORNOST! Ovaj aparat nije namijenjen osobama (uključujući djecu) koje imaju smanjene fizičke, osjetne ili mentalne sposobnosti, kao i osobama koje nisu dovoljnoiskusne i informirane, osim ako ih se nadgleda ili ako su dobile upute o uporabi aparata od osobe odgovorne za njihovu sigurnost.

POZORNOST! Kućni ljubimci moraju biti pod stalnim nadzorom te im se mora onemogućiti penjanje po aparatu, zavlacenje u isti, kao i griženje kablova. Prije uporabe aparata obavite provjeru!

POZORNOST! Osobama s ugrađenim srčanim stimulatorom preporučuje se konzultacija s liječnikom. Isto vrijedi za osobe s ugrađenim elektroničkim (npr. inzulinska pumpa) ili metalnim implantatima (npr. vijci i metalne pločice u kostima).

OPREZ! Ako je uz kuhalo isporučeno strugalom sa staklenom oštricom ili britvicom, tada treba biti posebno oprezan s uporabom jer može doći do povreda i posjekotina. Držati izvan dohvata djece !

POZORNOST! Kuhalo treba nadzirati tijekom njegova rada.

OPASNOST OD EKSPLOZIJE! Nije dozvoljeno zagrijavanje hrane ili tekućina u zatvorenim posudama ili konzervama, zbog širenja sadržaja uzrokovanog zagrijavanjem.

OPASNOST OD POŽARA! Pregrijano ulje ili mast mogu se brzo zapaliti na vrućoj zoni za kuhanje. Zbog toga tijekom pripreme hrane u ulju treba biti oprezan.

OPASNOST OD POŽARA! Nikada ne pokušavajte gasiti požar vodom nego isključite kuhalo te ugashite plamen tako da ga pokrijete poklopcem ili vatrootpornim platnom.

OPASNOST OD POŽARA! Nije dozvoljeno stavljati zapaljive materijale, tekućine čije se pare mogu zapaliti, na ili u blizinu kuhala koje je u uporabi.

OPREZ! Tijekom rada zagrijavaju se pojedini dijelovi aparata, ponajprije mjesta za kuhanje i njihova okolina. Nakon uklanjanja posude s hranom, površina za kuhanje ostaje neko vrijeme vruća. Ne dodirivati površinu jer može doći do opekline. Zbog toga se djeca ne smiju se zadržavati u blizini kuhala.

OPREZ! Ako se na staklokeramičkoj ploči pojave pukotine, prsnuća ili lomovi, nemojte je više rabiti, isključite sve prekidače zona za kuhanje, isključite kuhalo iz utičnice ili izvadite osigurač kako ne bi došlo do strujnog udara i pozovite nadležni servis.

OPREZ! Ne rabite abrazivna sredstva ili oštre metalne predmete kako biste očistili staklokeramičku ploču jer biste tako mogli zagrebat površinu stakla i uzrokovati pucanje i rasipanje stakla.

OPREZ! Staklokeramička ploča je vrlo otporna, ali nije nelomljiva! Posebno šiljasti i tvrdi predmeti koji padnu s visine mogu oštetiti staklokeramičku ploču.

OPREZ! Nije dopušteno staklokeramičku ploču rabiti kao radnu površinu, kao niti odlagati teške predmete na istu.

OPREZ! Pažljivo rukujte prilikom postavljanja. Rubovi ploče su oštri i može doći do posjekotina.

POZORNOST! Kuhalo može priključiti na električnu instalaciju u skladu s postojećim zakonskim propisima samo ovlaštena i stručno osposobljena osoba. Nestručno priključenje, modifikacije i popravci mogu uzrokovati električni udar i tjelesne ozljede, a za što proizvođač neće preuzeti nikakvu odgovornost.

POZORNOST! Kuhalo obvezatno mora biti uzemljeno!

POZORNOST! Aparat je predviđen za napon 220-240V~ 50/60 Hz, 16A. Pri priključenju treba voditi računa o tome da električna instalacija do mjesta na kojem se priključuje kuhalo bude takva da izdrži potrebnu struju.

POZORNOST! Kuhalo se ne smije priključivati na vanjski *timer* ili odvojeni daljinski upravljač.

POZORNOST! Ne uključujte aparat prije nego ga instalirate.

POZORNOST! Budite uvjereni kako priključni vod nije oštećen, prignječen ili zapetljan tijekom instalacije. Ne uključujte kuhalo u električnu instalaciju ako je priključni vod oštećen.

POZORNOST! Oštećeni priključni vod mora biti zamijenjen ispravnim, a smije ga zamijeniti jedino stručna osoba ili serviser. Nestručno priključenje i popravci mogu uzrokovati električni udar i tjelesne ozljede.

POZORNOST! Tijekom priključivanja električnih aparata u blizini kuhala mora se voditi računa o tome da njihov priključni kabel ne dođe u dodir s vrućim dijelovima kuhala.

POZORNOST! Nije dozvoljeno uključivati neispravni aparat, nego se isti treba isključiti iz električne mreže (vađenjem utičnice iz utikača ili isključenjem osigurača), a nakon toga je potrebno pozvati ovlaštenu servis.

POZORNOST! Ako dođe do nekog kvara na aparatu, nemojte ga popravljati sami jer u suprotnom može doći do većeg oštećenja aparata, za što proizvođač neće preuzeti odgovornost. Kvarove odstranjuju samo ovlaštenu serviseri.

POZORNOST! Kuhalo treba postaviti samo u zadovoljavajuće prozračnoj prostoriji. Pri intenzivnijoj uporabi kuhala potrebno je jače prozračivanje ili uključivanje nape.

POZORNOST! Kuhalo se ne smije čistiti visokotlačnim parnim aparatom za čišćenje, mlazom ili prskanjem vodom jer može doći do kratkog spoja i oštećenja kuhala.

POZORNOST! Nije dozvoljeno zagrijavanje praznih posuda bez hrane, jer može doći do oštećenja.

POZORNOST! Metalni objekti kao što su pribor za jelo i poklopci, metalne folije, limovi ili krpe ne smiju se stavljati na površinu kuhala jer bi se isti mogli zagrijati ili zapaliti te uzrokovati oštećenja, požar ili opekline.

POZORNOST! Posude za kuhanje uvijek stavljajte na sredinu zone za kuhanje, a držače posuda pomaknite u sigurni položaj kako se za njih ne bi zapelo rukom te prevrnulo.

POZORNOST! Za pridržavanje posuđa i tava rabite krpe ili rukavice kako biste izbjegli opekline.

POZORNOST! Aparatu najbliže susjedne stjenke, odnosno kuhinjski elementi (tlo, stražnji kuhinjski zid, bočni zidovi) moraju biti otporni na temperaturu od najmanje 100 °C.

POZORNOST! Zaštitite aparat od atmosferskih utjecaja (sunce, kiša, snijeg, prašina, vlaga, i sl.).

POZORNOST! Kuhalo ne smije služiti za zagrijavanje prostorija!

POZORNOST! Nikada nemojte, u blizini indukcijskog kuhala, ostavljati predmete koji bi se mogli oštetiti magnetskim poljem (npr. kreditne kartice, memorijske kartice slično) ili elektroničke uređaje (računala, mobitele, tablete i slično).

NAPOMENA! Nakon uporabe potrebno je isključiti kuhalo preko kontrolnog panela, a ne njegovom ugrađenom detekcijom metalnih posuda.

NAPOMENA! Ako se kuhalo ne koristi tada se mora isključiti preko odgovarajućeg senzora za uključenje/isključenje.

NAPOMENA! Nakon uključanja zone za kuhanje čuje se zujanje i škljocanje što je sasvim normalna pojava. To je zujanje svojstveno zagrijavanju indukcijom i ne djeluje na funkciju mjesta za kuhanje.

NAPOMENA! Ako se kuhalo ne koristi duži vremenski period (godišnji odmor i sl.), isključite ga iz električne mreže (vađenjem utikača iz utičnice ili isključite osigurač).

Ovaj je aparat namijenjen za korištenje u kućanstvima i sličnim okruženjima, kao što su:

- priručne kuhinje za osoblje u trgovinama, uredima i drugim radnim okruženjima;
- korištenje od strane gostiju u hotelima, motelima i drugim smještajnim prostorima;
- gospodarske zgrade i farme
- objekti koji nude usluge noćenja s doručkom.



U uputama za uporabu mogu biti opisani različiti tipovi aparata koji se međusobno razlikuju po opremljenosti i načinu rada, te mogu biti uključena i neka poglavlja koja za Vaš aparat ne dolaze u obzir.

Crteži su samo informativne naravi te ne moraju izgledati kao u stvarnosti.

Tehničke specifikacije proizvoda i ovaj priručnik podložni su promjenama bez prethodne obavijesti ili najave.

Pridržavamo pravo izmjena i grešaka u uputama za uporabu.

Proizvođač zadržava pravo promijeniti konstrukciju, mjere i težinu ako to smatra potrebnim radi poboljšanja kvalitete proizvoda, bez ugrožavanja osnovnih svojstava proizvoda. Tehničke specifikacije proizvoda samo su informativne naravi te su podložni promjenama bez prethodne obavijesti ili najave.

Tehnički podaci	
Model	UK302INDM
Broj kuhaćih zona	2
Napon / Frekvencija	220-240V~ 50/60Hz
Nazvina snaga (W)	3500W
Dimenzije kuhala (mm)	288X520X59,5
Ugradbena dimenzija (mm)	268X500

Informacijski list / Informacija o proizvodu	
Zaštitni znak dobavljača	KONČAR
Model	UK302INDM
Vrsta kuhala	električno
Broj kuhaćih zona ili područja	1 područje
Tehnologija zagrijavanja 1	indukcijsko kuhaće područje
Veličina 1	dužina 38,5cm širina 18cm
Potrošnja energije 1 po zoni za kuhanje ili području po kg	191,1 Wh/kg
Ukupna potrošnja energije po kg za električno kuhalo	191,1 Wh/kg
Kuhalo zadovoljava EN 60350-2:2013	

TEHNOLOGIJA INDUKCIJSKOG KUHANJA

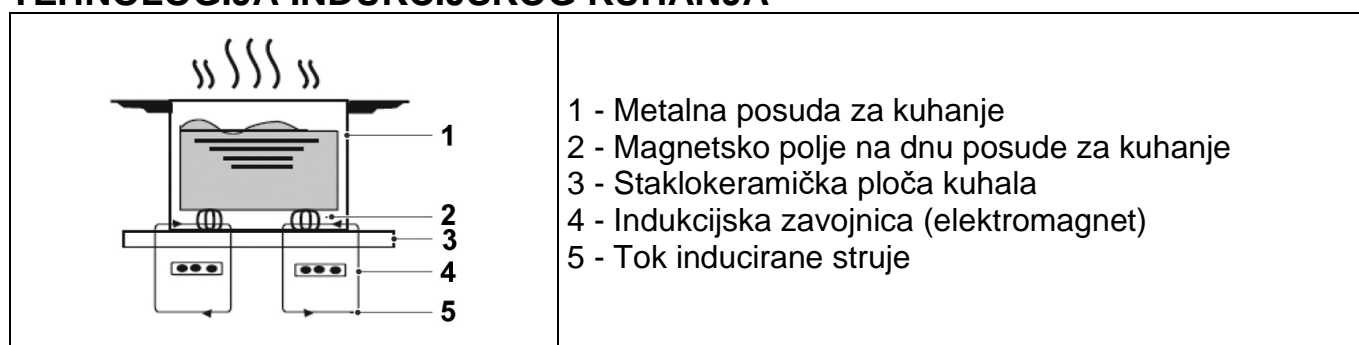

- 1 - Metalna posuda za kuhanje
- 2 - Magnetsko polje na dnu posude za kuhanje
- 3 - Staklokeramička ploča kuhala
- 4 - Indukcijska zavojnica (elektromagnet)
- 5 - Tok inducirane struje

Priprema hrane na indukcijskom kuhlalu je napredna, sigurna, učinkovita i ekonomski prihvatljiva tehnologija kuhanja. Princip rada zasniva se na elektromagnetskom polju, dobiveno izmjeničnom strujom, koje generira toplinu direktno na dnu metalne posude za kuhanje. Znači, nema indirektnog zagrijavanja pomoću radijantnog grijaćeg tijela ispod staklokeramičke ploče. U slučaju indukcijskog zagrijavanja, staklokeramička ploča postaje vruća samo i samo zbog prijenosa topline s dna metalne posude za kuhanje.

SKICA I OPIS APARATA

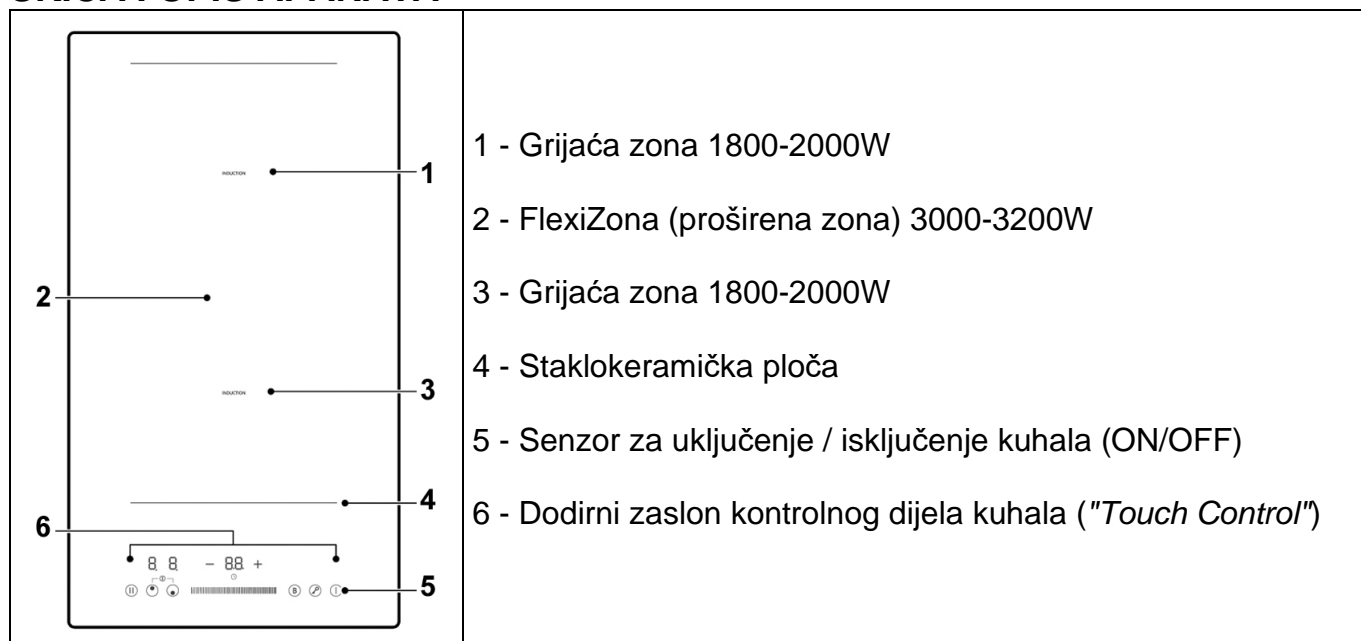

UPRAVLJAČKI ELEMENTI (SENZORI)

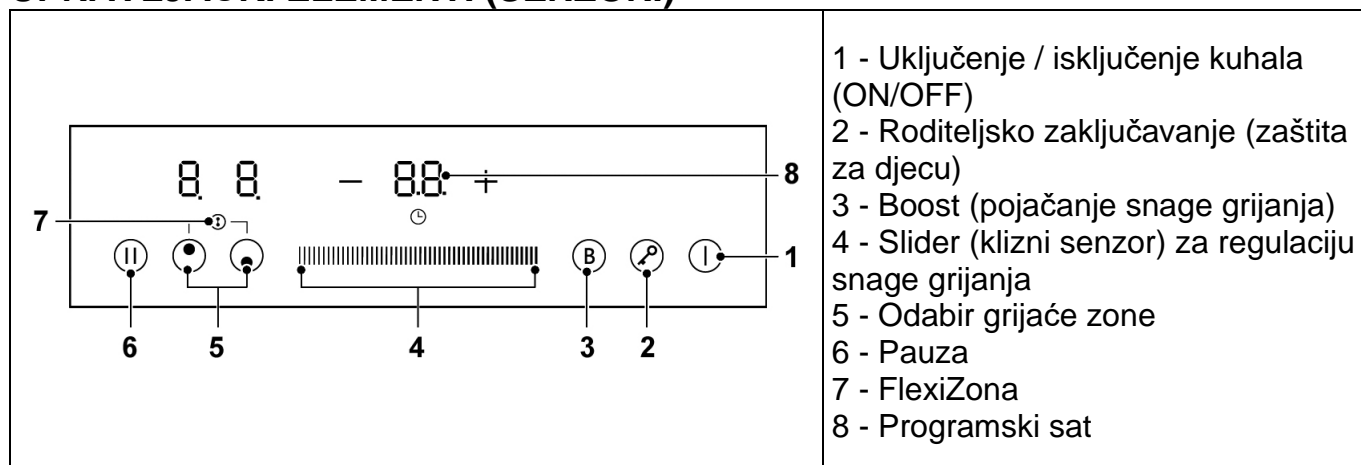

Ova staklokeramička kuhala su opremljena elektronskim dodirnim zaslonom, kojima se upravlja dodiranjem prsta na osjetilo - označeno mjesto ("Touch control").
 Kontrole reagiraju na dodir, pa nije potreban nikakav pritisak.
 Dodir je potvrđen i zvučnim signalom.

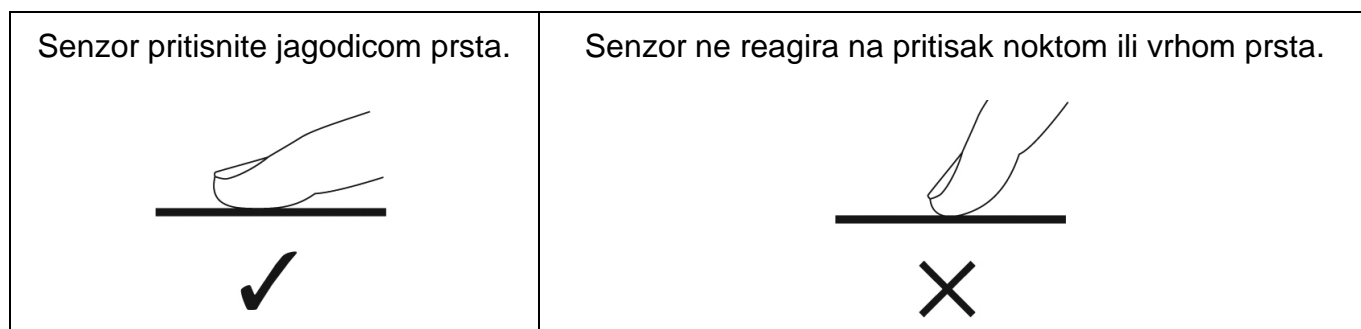

NAPOPMENA! Ne stavljajte nikakve predmete (pribor za jelo, krpe i sl.) na dodirni zaslon i uvijek ga održavajte suhim (čak i tanak sloj tekućine može onemogućiti kontrolu) i čistim.

ODABIR PRIKLADNOG POSUĐA ZA KUHANJE

NAPOMENA! Nikada ne uključujte zonu bez posude sa hranom.

Koristiti samo posuđe s debelim, ravnim i glatkim dnom, napravljeno od čelika, emajliranog čelika, ljevanog željeza (samo ako je tako označio proizvođač istoga). Provjerite specifikaciju proizvođača posuđa, jer je tamo naznačeno da li je posuđe pogodno za indukcijsko zagrijavanje.

Posuđe koje je prikladno za indukcijska kuhala obično su magnetska - približimo magnet i on se treba prihvatiti na površinu. Pravi INOX nije magnetski, iako ima nekih izuzetaka.

Ako magnet nije dostupan, tada se može iskoristiti samo kuhalo kako bi se ispitala posuda: Nalijte vodu u posudu te ju postavite na indukcijsku zonu. Ako simbol "u" ne treperi na displayu te se voda zagrijava - posuda je prikladna.

Kod nekih posuda mogu se čuti zujanja iz istih, ali to je normalna pojava i ne utječe na svojstva kuhanja.



Posuđe koje je neprikladno za uporabu je od stakla, keramike, bakra, aluminijska, INOXa ili sličnih nemagnetičnih materijala (postoje izuzeci, što ovisi o proizvođaču posuđa).

Posuđe s hrapavim ili deformiranim dnom nije preporučljivo stavljati na staklokeramičku ploču jer je može izgubiti ili loše nalijegati na istu.

Posuda se, sa zone za kuhanje, uvijek podiže prema gore, a ne ju povlačiti po površini ploče jer se ploča može izgubiti.

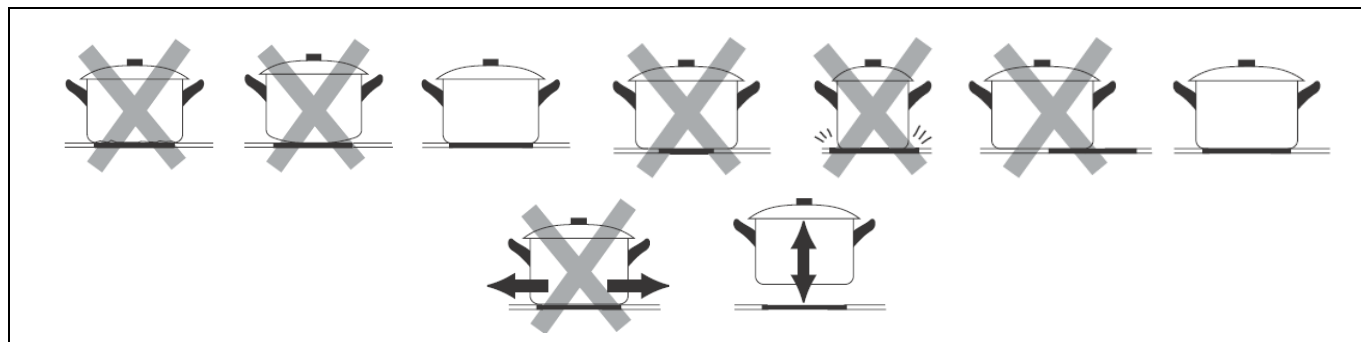

Staklokeramička ploča i dno posude moraju uvijek biti čisti: prljavština i ostaci hrane (posebno oni koji sadrže šećer) te zrnca pijeska ili ostaci sredstava za čišćenje mogu se zapeći na ploči i oštetiti je.

Prije stavljanja posude na mjesto za kuhanje, treba dobro obrisati dno posude da bi se omogućilo dobro provođenje topline. Dno posude ne smije biti vlažno.

Kuhajte uvijek u poklopljenom posuđu i pri tome pazite da poklopac dobro naliježe.

Kada jelo zakuha, smanjite temperaturu. Izbjegavajte prelijevanje tekućina na radnu ploču.

Uvijek pazite da u posudama uvijek bude dovoljno tekućine jer, zbog isparavanja, posuda može ostati prazna, a zbog pregrijavanja može doći do oštećenja posude i grijaće zone.

NAPOMENA! Nakon uporabe potrebno je isključiti kuhalo preko kontrolnog panela.

Zone za kuhanje se, iako u ograničenom nivou, automatski prilagode promjeru posude za kuhanje. Pa ipak, dno posude mora imati određeni promjer za određenu zonu za kuhanje. Kako bi se osigurala najbolja učinkovitost, izaberite uvijek odgovarajuću zonu za kuhanje prema posudi: dno posude i promjer zone trebaju biti podjednako veliki. Posuda treba biti pravilno pozicionirana, stoga pazite kod postavljanja posude da ista bude u sredini zone za kuhanje.

Kuhaća zona	Promjer dna posude za indukcijsko kuhanje	
180mm	min.140mm	max.180mm
180mm	min.140mm	max.180mm

UPORABA KUHALA

Nakon što se kuhalo priključi na električnu mrežu, svi se pokazivači uključe na kratko vrijeme. Nakon toga, kuhalo je u stanju pripravnosti te je spremno za uporabu.

POČETAK KUHANJA

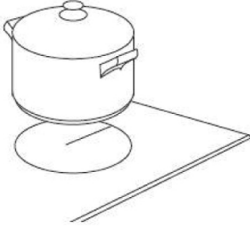
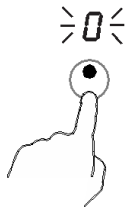
<p>Kuhalo se uključuje pritiskom na senzor za uključenje / isključenje kuhala. Oglašava se zvučni signal. Svi displayi ispisuju simbole "-" ili "- -". Kuhalo je u stanju pripravnosti.</p>	
<p>Postavite odgovarajuću posudu (napunjenu hranom) na željenu zonu za kuhanje. Uvjerite se kako su dno posude i zona za kuhanje, čisti i suhi.</p>	
<p>Pritisnite senzor za odabir zone za kuhanje. Display za tu zonu početi će treperiti.</p>	

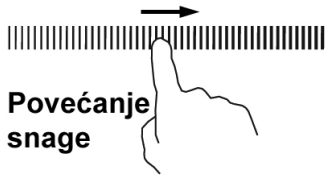
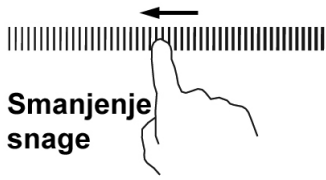

<p>Temperaturu (snagu grijanja) odabrane grijaće zone regulirate klizanjem prsta po kliznom senzoru (slideru).</p> <p>Ukoliko u roku od 1 minute ne aktivirate rad niti jedne grijaće zone, kuhalo se automatski isključuje.</p> <p>Promjena temperature moguća je u svakom trenutku kuhanja.</p>	 <p>Povećanje snage</p>  <p>Smanjenje snage</p>
---	---

NAPOMENA! Ako se na displayu pojavi simbol  koji treperi, to može značiti slijedeće:

- Posuda za kuhanje nije postavljena na odgovarajuću kuhaću zonu.
- Posuda nije od odgovarajućeg materijala za indukcijsko kuhanje.
- Posuda je premala ili nije korektno centrirana na kuhaću zonu.

Kuhalo neće započeti s radom ako na kuhaćoj zoni nije postavljena odgovarajuća posuda. Display će se automatski isključiti nakon 2 minute ako na kuhaćoj zoni nije postavljena odgovarajuća posuda.

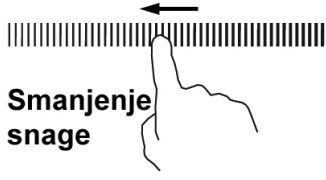
ZAVRŠETAK KUHANJA

<p>Pritisnite senzor za odabir zone za kuhanje, a koju želite isključiti.</p>	
<p>Odabrana zona se isključuje klizanjem prsta po slideru dok se na displayu ne pokaže "0".</p> <p>Budite uvjereni da display prikazuje "0".</p>	 <p>Smanjenje snage</p>
<p>Kuhalo se isključuje pritiskom na senzor za uključenje / isključenje kuhala.</p>	

POZORNOST! Opasnost od opekline!**Preostala temperature rada (zaostala toplina)**

Po završetku pripreme hrane, staklokeramička ploča zadržava određenu temperaturu koja se naziva zaostala toplina, a može biti opasna jer može uzrokovati opekline. Nakon isključenja grijaće zone, ukoliko je temperatura visoka, biti će prikazan simbol "H". Simbol ostaje prikazan sve dok vrijednost temperature ne padne na sigurnu razinu.

**PROŠIRENO PODRUČJE ZA KUHANJE - FLEXIZONA**

Ovo se područje može koristiti kao jedna velika zona ili dvije zone, ovisno o potrebama za kuhanje. Područje se sastoji od dvije neovisne indukcijske jedinice koje se mogu neovisno kontrolirati.

Jedna velika zona

<p>Kako bi se aktivirala jedna velika zona (FlexiZona), pritisnuti senzore.</p>	
<p>Preporuka je da se koristi posuda promjera 250 do 280mm, a također je prihvatljiva ovalna ili pravokutna posuda. Ne preporučuju se ostale operacije od ovih preporučenih, jer se može poremetiti grijanje kuhala.</p>	

Dvije neovisne zone

<p>Kako bi se FlexiZona područje moglo koristiti kao dvije različite zone, moguće je imati dva izbora zagrijavanja posuda.</p> <p>NAPOMENA: Posude moraju imati promjer veći od 120mm.</p>	<p>Postaviti posudu na gornju ili donju stranu područja.</p>	<p>Postaviti dvije posude na obje strane područja.</p>
---	--	--

RODITELJSKO ZAKLJUČAVANJE (ZAŠTITA ZA DJECU)

Ovom funkcijom možete zaključati (onemogućiti uporabu) senzore na kontrolnom zaslonu čime onemogućujete neželjeno korištenje (npr. kako djeca ne bi uključila zone za kuhanje).

U slučaju da je ova funkcija aktivirana, moguće je jedino koristiti senzor za uključanje / isključenje.

Za aktivaciju zaključavanja pritisnuti senzor . Kao potvrda uključanja funkcije, biti će prikazan simbol "Lo".

Kako bi se funkcija isključila, kuhalo mora biti uključeno. Nakon toga je potrebno pritisnuti i držati senzor .





Kada je kuhalo je u potpunosti zaključano, dostupan je jedino senzor za uključanje / isključenje , kojim uvijek možete uključiti kuhalo, ali prije svih drugih operacija morate isključiti funkciju zaključavanja.

VREMENSKI SAT (TIMER)

Vremenski sat se može koristiti na dva načina.

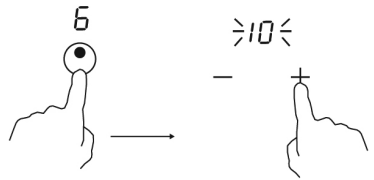



1. Brojač minuta. U tom slučaju, timer neće isključiti nijednu zonu kad postavljeno vrijeme istekne.
2. Isključenje jedne ili više zona za kuhanje kad postavljeno vrijeme istekne. Maksimalno vrijeme je 99 minuta.

1. Brojač minuta, ako nije odabrana niti jedna zona za kuhanje.

<p>Kuhalo mora biti uključeno. Kad pritisnete senzor vremenskog sata, na displayu timera treperi "10".</p>	
<p>Podesite vrijeme pritiskom na senzore "-" ili "+". Pritisnuti jednom senzor "-" ili "+" pa će se vrijeme smanjivati ili povećavati po 1 minutu. Pritisnuti i držati senzor "-" ili "+" pa će se vrijeme smanjivati ili povećavati po 10 minuta.</p>	
<p>Ako istovremeno pritisnete "-" i "+", timer se poništava, a na displayu se prikazuje "00".</p>	
<p>Kada je vrijeme postavljeno, odmah počinje odbrojavanje. Na displayu će se prikazati preostalo vrijeme i indikator timera treperit će 5 sekundi.</p>	
<p>Oglasiti će se zvučni signal u trajanju od 30 sekundi, a indikator timera pokazuje "- -" kad podešeno vrijeme istekne.</p>	

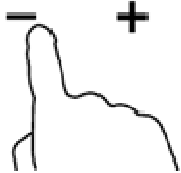
2. Postavljanje vremenskog sata da isključi jednu ili više zona za kuhanje.

Podešavanje za jednu zonu:

<p>Pritisnete senzor zone na kojoj želite koristiti vremenski sat.</p>	
<p>Podesite vrijeme pritiskom na senzore "-" ili "+". Pritisnuti jednom senzor "-" ili "+" pa će se vrijeme smanjivati ili povećavati po 1 minutu. Pritisnuti i držati senzor "-" ili "+" pa će se vrijeme smanjivati ili povećavati po 10 minuta.</p>	
<p>Ako istovremeno pritisnete "-" i "+", timer se poništava, a na displayu se prikazuje "00".</p>	
<p>Kada je vrijeme postavljeno, odmah počinje odbrojavanje. Na displayu će se prikazati preostalo vrijeme i indikator timera treperit će 5 sekundi. Crvena točkica pokraj indikatora razine snage označit će da je zona za kuhanje odabrana.</p>	
<p>Kad istekne vrijeme kuhanja, podešena zona za kuhanje automatski će se isključiti. Napomena: Ostale zone za kuhanje nastavljaju s radom ako su prije toga bile uključene.</p>	

FUNKCIJA POVEĆANJA SNAGE GRIJANJA - BOOST

Ovom se funkcijom uključuje najveća snaga bilo koje kuhaće zone.

Pošto ovaj način rada ne može dugo trajati, normalno stanje rada kuhaće zone vraća se nakon 5 minuta.



Ako je originalna postavka grijanja postavljena na 0, ista će se vratiti na vrijednost 9 nakon 5 minuta.

Aktiviranje funkcije Boost

<p>Pritisnete senzor zone na kojoj želite koristiti Boost funkciju.</p>	
---	---

<p>Pritisnete senzor za Boost. Display će prikazati simbol "P".</p>	
---	---

Poništenje funkcije Boost

<p>Pritisnete senzor zone na kojoj želite isključiti (poništiti) Boost funkciju.</p>	
<p>Pritisnete senzor za Boost. Funkcija će biti isključena. Budite uvjereni da display prikazuje "0".</p>	

OGRANIČENJE VREMENA RADA KUHAĆE ZONE

Automatsko isključivanje je još jedna od sigurnosnih značajki kuhala. To se događa u slučaju da zaboravite isključiti zonu za kuhanje. Zadana vremena isključenja prikazana su u tablici:

Razina snage	1	2	3	4	5	6	7	8	9
Maksimalno dozvoljeno vrijeme rada (sati)	8	8	8	4	4	4	2	2	2

Ako se posuda za kuhanja ukloni tada će zona trenutno prestati zagrijavati, a indukcijsko kuhalo će se automatski isključiti nakon 2 minute.

DETEKCIJA MALENIH PREDMETA

Ako se slučajno na kuhalu ostave maleni metalni nemagnetični predmeti (npr. malena aluminijska posuda, folija, i sl.) ili maleni magnetični predmeti (npr. nož, vilica, ključeni, i sl.), tada, nakon 1 minute, kuhalo automatski prelazi u stanje pripravnosti. Ventilator u kuhalu će dodatno raditi još jednu minutu.

AUTOMATSKI PRIJELAZAK U MOD PRIPRAVNOSTI

Ako se, nakon uključenja kuhala, ne izvrši niti jedna funkcija (pritisak na senzor ili podešavanja), tada će se kuhalo automatski isključiti nakon 1 minute, te prijeći u stanje pripravnosti. Potrošnja električne energije u stanju pripravnosti iznosi 0,5W.

UPUTE I SAVJETI ZA UPORABU KUHALA

	<p>POZOR! OPASNOST OD OPEKLINA! Tijekom rada zagrijavaju se pojedini dijelovi kuhala, ponajprije mjesta za kuhanje i njihova okolina. Visoka temperatura može biti visoka i nakon kuhanja.</p> <p>OPASNOST OD POŽARA! Nikada ne ostavljajte predmete na površini za kuhanje! Priprema hrane u ulju ili na masti zahtijeva oprez jer se pregrijano ulje ili mast mogu brzo zapaliti i uzrokovati požar. NIKADA ne pokušavajte gasiti požar vodom nego isključite kuhalo te ugascite plamen tako da ga pokrijete poklopcem ili vatrootpornim platnom.</p>
---	---

Napomena: Savjeti daju primjere kako hranu treba pripremati i imaju ulogu samo općeg vodiča jer svatko kuha prema vlastitim navikama i iskustvima.

Kad jelo proključa, snizite temperaturu kuhanja.

Korištenje poklopca skratit će vrijeme kuhanja i štedi energiju zadržavanjem topline.

Minimizirajte količinu tekućine ili masnoće kako biste skratili vrijeme kuhanja.

Započnite kuhati na visokim temperaturama i smanjite ih kad se hrana zagrije.

Pirjanje se odvija ispod točke vrenja, na oko 85 °C, kad mjehurići tek povremeno izbijaju na površinu. Ključ je za ukusne juhe i blage gulaše jer se okusi razvijaju bez prekuhavanja hrane. I umake na bazi jaja i brašna također kuhate ispod točke vrenja.

Neki zadaci, poput kuhanja riže apsorpcijskom metodom, mogu zahtijevati postavljanje više temperature od najniže vrijednosti kako bi se jelo skuhalo u preporučenom vremenu.

Za pripremu sočnog odreska:

1. Neka meso odstoji na kućnoj temperaturi oko 20 minuta prije kuhanja.
2. Zagrijte tavu s teškom osnovom.
3. Obje strane odreska premažite uljem. U vruću tavu ulijte malo ulja, a zatim spustite meso na vruću tavu.
4. Odrezak okrenite samo jednom tijekom kuhanja. Vrijeme kuhanja ovisi o debljini odreska i načinu na koji ga želite skuhati. Vrijeme može varirati 2 - 8 minuta po strani odreska. Pritisnite odrezak kako biste utvrdili koliko je kuhan - što se čvršće osjeća to je "jače pečen".
5. Ostavite odrezak nekoliko minuta na tanjuru kako bi se opustio i omekšao prije serviranja.

Prženje:

1. Izaberite wok ravnog dna ili veliku tavu prikladnu za kuhanje na staklokeramičkoj ploči.
2. Pripremite sve potrebne sastojke i pribor. Prženje miješanjem treba biti brzo. Ako kuhate veće količine, kuhajte hranu u nekoliko manjih posuda.
3. Dobro zagrijte tavu i dodajte dvije žlice ulja.
4. Prvo skuhanje meso, stavite sa strane i održavajte mu toplinu.
5. Prženje povrća: Dok je povrće vruće, ali još uvijek hrskavo, snizite temperaturu polja za kuhanje, vratite meso u tavu i dodajte umak.
6. Nježno miješajte sastojke kako biste bili sigurni da su posve zagrijani.
7. Odmah poslužite.

UPRAVLJANJE KUHAĆIM ZONAMA - POSTAVKE NA DISPLAYU

Odaberite odgovarajuću temperaturu ovisno o vrsti jela.

U tablici se nalaze samo orijentacijske vrijednosti kao vodič.

Realne vrijednosti ovise o vrsti posuđa za kuhanje, vrsti i količini hrane. Ponekad je potrebno pokusom utvrditi najbolje postavke za kuhanje.

Postavka	Uporaba
1 - 2	blago zagrijavanje malih količina hrane , topljenje čokolade, maslaca i hrane koja brzo izagara, blago pirjanje, sporo zagrijavanje
3 - 4	podgrijavanje, brzo pirjanje, kuhanje riže
5 - 6	palačinke
7 - 8	kuhanje, kuhanje tjestenine
9	prženje miješanjem, prženje, vrenje juhe, prokuhavanje vode

ČIŠĆENJE I ODRŽAVANJE

	<p>Prije čišćenja kuhala pričekajte da se kuhalo ohladi na sigurnu temperaturu. Obvezatno isključite kuhalo iz električne instalacije: izvadite osigurač ili isključite LS-automat ili izvadite utikač iz utičnice.</p> <p>Kuhalo se ne smije čistiti visokotlačnim parnim aparatom za čišćenje jer može doći do kratkog spoja i oštećenja kuhala.</p>
---	--

Ako je kuhalo još uvijek zagrijano (treperi simbol "**H**") i ako želimo izbjeći opekline, tada je potrebno je pričekati da se kuhalo ohladi. Ako je kuhalo isključeno s električne mreže, neće biti indikatora "vruće površine", ali zona za kuhanje još uvijek može biti vruća ! Budite jako oprezni.

Čistite staklokeramičku ploču uvijek kada je malo prljava - najbolje poslije svake uporabe jer se inače kod svake sljedeće uporabe i najmanja nečistoća zapeče na vruću površinu .

Za to koristite vlažnu krpu s malo deterdženta za ručno pranje posuđa. Nakon toga osušite je čistom krpom ili papirnatim ručnikom. Ne smije biti ostataka ostatke čišćenja i deterdženta na površini. Prašinu sa površine treba čistiti vlažnom krpom.

Ne rabite abrazivna sredstva ili oštre metalne četke ili žice za čišćenje jer mogu oštetiti staklo i uzrokovati njegov lom.

Zagorjeli šećer ili rastoplenu plastičnu masu odstraniti odmah, dok je vruće, staklenim strugalom ili britvicom, a zatim očistiti deterdžentom. Uklonite s površine zrnca pijeska ili sl. koja bi mogla oštetiti staklokeramičku ploču.

Mrlje od kamenca i sjajne sedefaste mrlje nastale tijekom kuhanja odstraniti strugalom sa staklenom oštricom ili britvicom i ponoviti postupak s deterdžentom.

Ako dođe do proljevanja tekućine preko senzora za kontrolu tada se mogu javiti zvučni signali, a senzori neće reagirati jer je na njima tekućina. Potrebno je isključiti kuhalo s električne mreže, upiti i obrisati prelivenu tekućinu, obrisati područje senzora čistom spužvom ili krpom, te ih potpuno posušiti suhom krpom ili papirnatim ručnikom, ponovno uključiti kuhalo na električnu mrežu.

Tijekom vremena može doći do promjene boje staklokeramičke ploče, što je normalna pojava, te ne utječe na strukturu ili otpornost materijala. **Promjena boje ploče nije predmet reklamacije.**

Razlozi u promjeni boje mogu biti nečišćenje prolivene hrane, uporaba neadekvatnog posuđa za kuhanje koje erodiraju površinu, ili neadekvatnog sredstva za čišćenje.

MOGUĆI PROBLEMI I NJIHOVO RJEŠAVANJE

Ukoliko Vaš aparat ne radi ispravno, uzrok bi mogla biti neka sitnica. Kako biste uštedijeli vrijeme i novac prije pozivanja servisera, provjerite sljedeće:

Problem	Mogući uzrok	Moguće rješenje
Upravljački dio kuhala ne svjetli. Kuhalo se ne može uključiti.	Nema dotoka električne energije.	Provjerite da li je kuhalo priključeno na električnu instalaciju. Provjerite da li ostali aparati također rade. Pregorio je osigurač. Provjerite je li osigurač odgovarajući. Ako se problem ponavlja, pozovite servis.
Senzori ne reagiraju.	Uključeno je roditeljsko zaključavanje (zaštita za djecu).	Isključiti roditeljsko zaključavanje.
Senzorima se teško upravlja.	Možda se na senzorima stvorio tanak sloj vlage. Mokri senzori. Senzori su prekriveni predmetom ili ih pokušavate regulirati vrhom prsta.	Budite sigurni da je područje dodirnih senzora suho, da nisu prekriveni predmetima i pri dodiru koristite jagodicu prsta.
Staklo je izgrebano.	Posuđe s grubim rubovima. Upotrebljavaju se neprikladna sredstva ili abrazivni proizvodi za čišćenje.	Pogledajte "Odabir prikladnog posuđa za kuhanje". Pogledajte "Čišćenje i održavanje".
Neke posude pucketaju ili se čuju drugi zvukovi.	Uzrok može biti konstrukcija vašeg posuđa (slojevi različitih metala različito vibriraju).	To je uobičajena pojava.
Kuhalo proizvodi zvukove brujanja pri visokim postavkama za zagrijavanje.	Ovo je uzrokovano samom tehnologijom indukcijskog zagrijavanja.	Ovo je normalna pojava, iako se brujanje utiša pri nižim postavkama zagrijavanja.
Zvuk (šum) ventilatora dolazi iz kuhala.	Ventilator za hlađenje unutrašnjosti kuhala sprječava pregrijavanje elektroničkih sklopova. Isti nastavlja s radom neko vrijeme iako je kuhalo isključeno.	Ovo je normalna pojava. Nije potrebno odspojiti kuhalo s električne mreže dok ventilator radi.

Problem	Mogući uzrok	Moguće rješenje
Kuhalo se isključuje tijekom uporabe	Jedna od kuhaćih zona predugo je uključena.	Zona se može ponovno koristiti nakon što se kuhalo ohladi i uključi.
Posude za kuhanje se ne zagrijavaju.	Kuhalo ne može detektirati posudu jer nije pogodna za indukcijsko kuhanje. Posuda je premalena. Posuda nije centrirana na sredinu kuhaće zone.	Koristiti posuđe namijenjeno za indukcijsko kuhanje odgovarajuće veličine. Centrirati posudu na sredinu kuhaće zone.
Kuhalo ili zone se isključuju bez razloga, javlja se zvučni signal i poruka greške na displayu.	Tehničke greške u kuhalu.	Provjeriti kodove grešaka i poduzeti potrebne akcije.
Abnormalna buka unutar kuhala.	Oštećenje ventilatora	Isključiti kuhalo i pozvati servis.

KODOVI GREŠAKA

Ako se pojave greške prilikom uporabe kuhala, tada će iste biti prikazane na zaslonu kuhala.

Kod greške	Mogući uzrok	Moguće rješenje
E1	Greška na nekom od temperaturnih senzora.	Pozovite ovlaštenu servis.
E2		
E3		
E4		
E7		
C1	Previsoka temperatura unutar kuhala.	Pričekajte da se kuhalo ohladi, te ga ponovno uključite pritiskom na senzor za uključivanje / isključivanje kuhala. Ako se stanje ne normalizira, pozovite ovlaštenu servis.
C2	Previsoka temperatura elektronike kuhala.	Pričekajte da se temperatura vrati na normalu. Ponovno uključite kuhalo pritiskom na senzor za uključivanje / isključivanje. Ako se stanje ne normalizira, pozovite ovlaštenu servis.
EL	Preniski napon u električnoj mreži.	Pričekajte da se napon mreže vrati na normalu. Ponovno uključite kuhalo pritiskom na senzor za uključivanje / isključivanje.
EH	Previsoki napon u električnoj mreži.	Pričekajte da se napon mreže vrati na normalu. Ponovno uključite kuhalo pritiskom na senzor za uključivanje / isključivanje.
EU	Greška u prijenosu podataka unutar kuhala.	Pozovite ovlaštenu servis.

UPUTE ZA POSTAVLJANJE I PRIKLJUČENJE

	<p>Postavljanje i priključak kuhala može obaviti jedino ovlaštena i stručno osposobljena osoba, a u skladnosti s trenutnim državnim zakonima, normama, direktivama, te ostalim regulativama.</p> <p>Nepropisna i nestručna instalacija može biti opasna te uzrokovati povrede i oštećenja. Proizvođač/distributor u tom slučaju ne preuzima odgovornost, a jamstvo ne vrijedi.</p> <p>Nije dozvoljena uporaba aparata ako nije propisno postavljen i priključen.</p>
---	---

POSTAVLJANJE KUHALA

	<p>Kuhalo se može postaviti samo u zadovoljavajuće prozračnim prostorijama! Pri tome treba paziti da budu zadovoljeni propisi o veličini i provjetravanju prostorije tj. izmjeni zraka (prirodnim putem, pomoću ventilatora za izmjenu zraka ili pomoću kuhinjske nape).</p> <p>Pogledajte da li kuhalo ima ikakvih oštećenja nastalih u transportu. Pažljivo rukujte prilikom postavljanja. Budite oprezni - rubovi ploče su oštri. Nepridržavanje ovih uputa može rezultirati ozljedom.</p> <p>Ne instalirati blizu zapaljivih dijelova namještaja (npr. zavjesa). Ne postavljati na aparate za hlađenje, perilice posuđa ili sušilice rublja.</p> <p>Aparatu najbliže susjedne stjenke, odnosno kuhinjski elementi (tlo, stražnji kuhinjski zid, bočni zidovi) moraju biti otporni na temperaturu od najmanje 100 °C.</p> <p>Radna ploča na koju se ugrađuje kuhalo mora biti otporna na temperature veće od 100 °C te minimalne debljine 30mm.</p> <p>Ljepilo koje spaja plastiku ili drvene materijale mora imati otpornost na temperature ne veće od 150°C, kako biste izbjegli odvajanje oplate.</p>
---	---

Izrežite radnu površinu prema mjerama prikazanim na crtežu.

Za potrebe ugradnje i uporabe oko otvora ostavite najmanje 5 cm prostora.

Budite sigurni da je radna površina debela najmanje 30 mm. Odaberite izoliranu radnu površinu od materijala otpornog na toplinu (drvo i slični vlaknasti ili higroskopni materijali ne smiju se koristiti kao radna površina osim ako su impregnirani) kako biste izbjegli opasnost od strujnog udara i veća oštećenja uzrokovana toplinskim zračenjem zona za kuhanje.

Slijedite korake u nastavku:

Napomena: Sigurna udaljenost između unutrašnjih stranica kuhala i unutarnje površine radne ploče mora biti najmanje 3 mm.

	A	268 - 272 mm
	B	500 - 504 mm
	C	min. 50mm
	D	min. 50mm
	E	min. 50mm
	F	min. 50mm
	G	min. 3mm

Staklokeramičko kuhalo sada se može ugraditi na gornju plohu kuhinjskog elementa.
Ploču treba postaviti vodoravno.

NAPOMENA! Staklokeramička ploča za kuhanje mora imati osiguranu dobru ventilaciju te da ulaz i izlaz zraka nisu blokirani. Ako se kuhalo instalira iznad ladice ili paznog prostora u elementu, tada se mora ugraditi separator otporan na visoke temperature. Okomiti razmak između kuhala i nape mora biti najmanje onakav kakav je naznačen u uputama za postavljanje nape, a ako nape nema, razmak do gornjeg kuhinjskog elementa ili ormarića mora biti min. 76cm.

	A	760 mm
	B	min. 50mm
	C	min. 20mm
	D	Ulaz zraka
	E	Izlaz zraka 5mm



POZORNOST! Kuhalo mora imati osiguranu odgovarajuću ventilaciju !

Ventilacijski otvori nalaze se na vanjskoj strani kućišta kuhala.
MORATE osigurati da ti otvori nisu blokirani kada ugradbeno kuhalo postavite na radnu površinu.

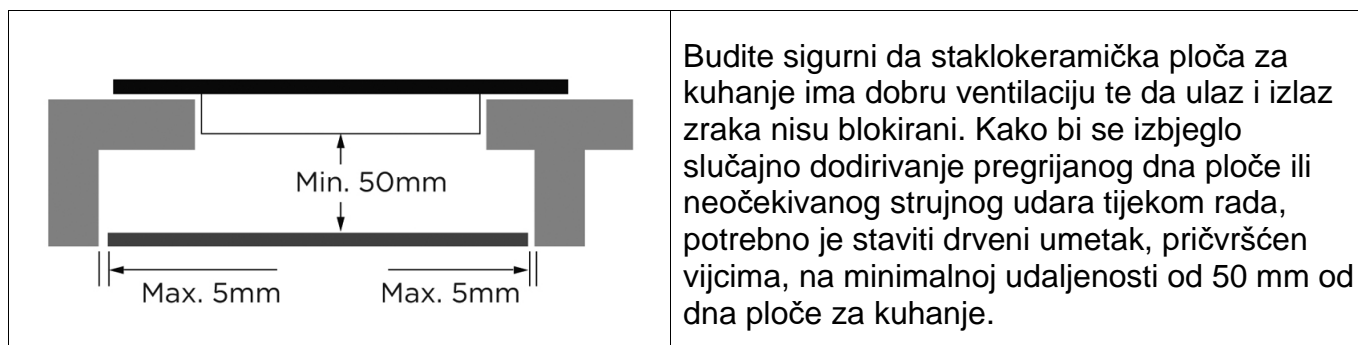

Nakon izrezivanja otvora i pripreme, očistite element te pripremite kuhalo.

Brtvu postavite po unutarnjem obodu radne ploče. Ne rastežite brtvu.

Očistite površinu radnog površinu od nečistoća, stavite staklokeramičku ploču u otvor i čvrsto pritisnite na radnu površinu.

Pažljivo odstranite višak brtve ako je izašao između kuhala i radne ploče. Kuhalo mora stajati vodoravno.

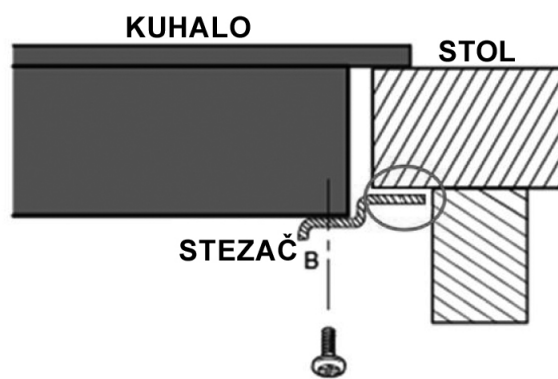
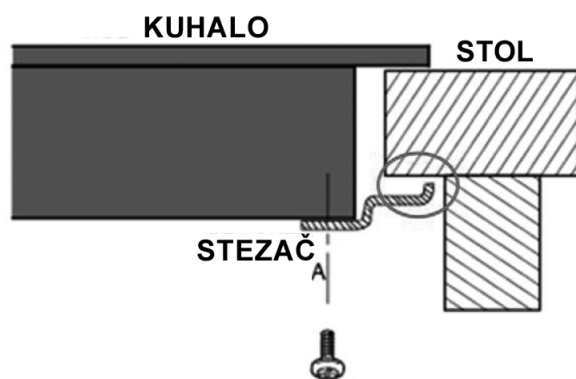
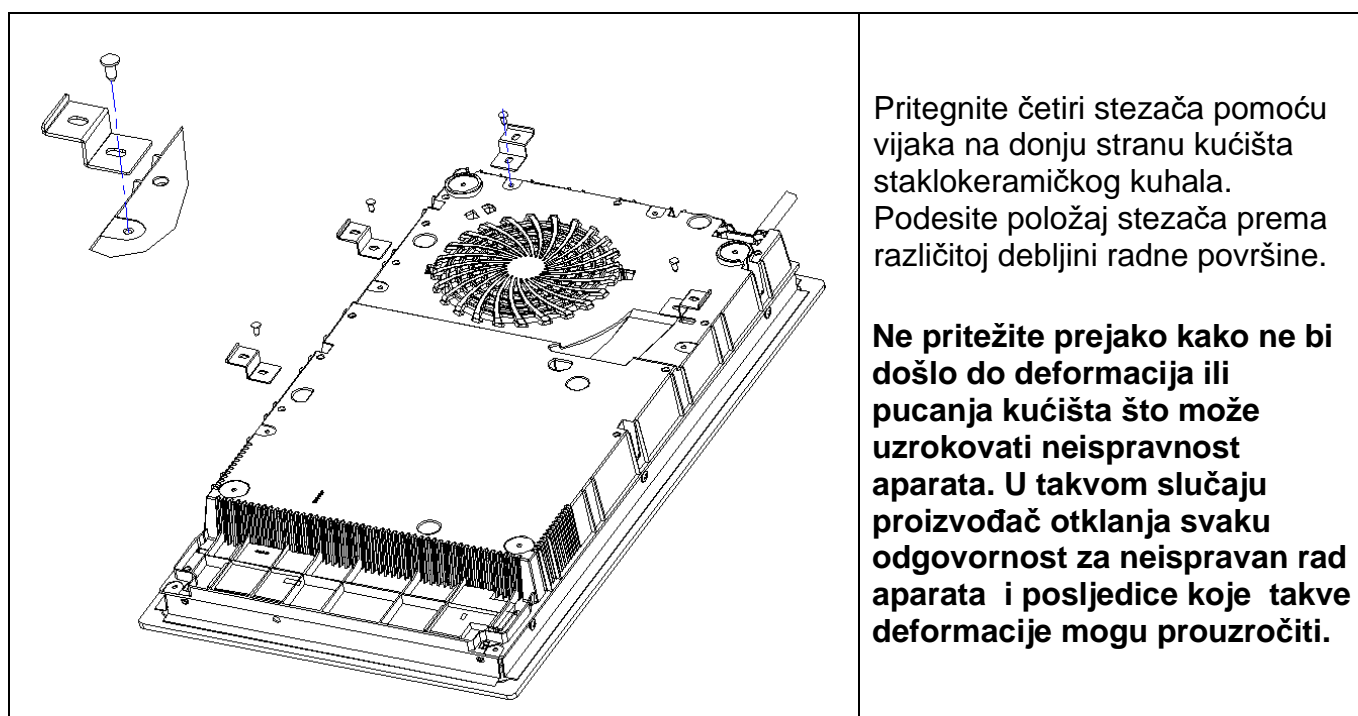

POZORNOST! Ni pod kojim uvjetima, nosači nakon postavljanja ne smiju dodirivati unutarnje dijelove radne površine (pogledajte sliku).

PRIKLJUČAK KUHALA NA ELEKTRIČNU INSTALACIJU

	<p>POZOR! Priključak kuhala na električnu instalaciju može obaviti jedino ovlaštena i stručno osposobljena osoba.</p> <p>POZOR! Kuhalo obvezatno mora biti uzemljeno! Električna sigurnost kuhala zajamčena je jedino ako je ono ispravno spojeno na ispravnu električnu instalaciju s uzemljenjem.</p> <p>Tijekom priključenja treba voditi računa da električna instalacija do mjesta gdje se priključuje kuhalo bude takva da izdrži potrebnu struju.</p> <p>Nepropisna i nestručna instalacija može biti opasna te uzrokovati povrede i oštećenja. Proizvođač/distributor u tom slučaju ne preuzima odgovornost, a jamstvo ne vrijedi.</p> <p>Nije dozvoljena uporaba aparata ako nije propisno postavljen i priključen.</p>
---	---

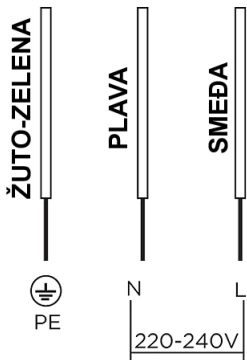
	<p>Kuhalo je tvornički priređeno za priključak na jednofaznu električnu instalaciju 230 V ~.</p> <p>Kuhalo se priključuje na propisno instaliranu zidnu priključnicu s kontaktom za uzemljenje s vlastitim strujnim krugom i osiguračem od 16 A.</p> <p>Fazni vodič L obično je crne ili smeđe boje. Neutralni vodič N (nula) obično je plave boje. Zaštitni vodič PE (uzemljenje) je žuto-zelene boje.</p>
---	---

Električni priključak mora biti trajan (a ne pomoću utikača i utičnice), preko sklopki za odvajanje svih polova od čvrste električne instalacije prema nacionalnim propisima za izradu električne instalacije odgovarajućeg napona.

Zidna priključnica mora biti lako pristupačna (zbog propisa o mogućnosti odvajanja svih polova s električne instalacije) i ne smije biti izložena toplinskom zračenju.

Priključni vod treba biti udaljen od izvora topline i ne smije se zagrijavati (zbog električnog opterećenja).

POZORNOST! Budite uvjereni kako priključni vod nije oštećen, prignječen ili zapetljan tijekom instalacije. Ne uključujte kuhalo u električnu instalaciju ako je priključni vod oštećen.

POZORNOST! Oštećeni priključni vod mora biti zamijenjen ispravnim, a smije ga zamijeniti jedino stručna osoba ili serviser. Nestručno priključenje i popravci mogu uzrokovati električni udar i tjelesne ozljede.

NAPOMENA ! Donja površina i priključni vod kuhala nisu dostupni nakon ugradnje.

Induction Hob

Instruction Manual / Installation Manual

Content

1. Foreword	5
1.1 Safety Warnings	5
1.2 Installation	5
1.2.1 Electrical Shock Hazard	5
1.2.2 Cut Hazard	5
1.2.3 Important safety instructions	5
1.3 Operation and maintenance	6
1.3.1 Electrical Shock Hazard	6
1.3.2 Health Hazard	6
1.3.3 Hot Surface Hazard	7
1.3.4 Cut Hazard	7
1.3.5 Important safety instructions	7
2. Product Induction	9
2.1 Top View	9
2.2 Control Panel	9
2.3 Working Theory	10
2.4 Before using your New Induction Hob	10
2.5 Technical Specification	10
3. Operation of Product	10
3.1 Touch Controls	10
3.2 Choosing the right Cookware	11
3.3 How to use	12
3.3.1 Start cooking	12
3.3.2 Finish cooking	13
3.3.3 Locking the Controls	13
3.3.4 Timer control	15
3.3.5 Default working times	16
4. Cooking Guidelines	18
4.1 Cooking Tips	18
4.1.1 Simmering, cooking rice	18
4.1.2 Searing steak	18
4.1.3 For stir-frying	18
4.2 Detection of Small Articles	18
5. Heat Settings	19
6. Care and Cleaning	19
7. Hints and Tips	20
8. Failure Display and Inspection	21
9. Installation	23
9.1 Selection of installation equipment	23
9.2 Before installing the hob, make sure that	24
9.3 After installing the hob, make sure that	24
9.4 Before locating the fixing brackets	25
9.5 Adjusting the bracket position	25
9.6 Cautions	26
9.7 Connecting the hob to the mains power supply	26

1. Foreword

1.1 Safety Warnings

Your safety is important to us. Please read this information before using your cooktop.

1.2 Installation

1.2.1 Electrical Shock Hazard

- Disconnect the appliance from the mains electricity supply before carrying out any work or maintenance on it.
- Connection to a good earth wiring system is essential and mandatory.
- Alterations to the domestic wiring system must only be made by a qualified electrician.
- Failure to follow this advice may result in electrical shock or death.

1.2.2 Cut Hazard

- Take care - panel edges are sharp.
- Failure to use caution could result in injury or cuts.

1.2.3 Important safety instructions

- Read these instructions carefully before installing or using this appliance.
- No combustible material or products should be placed on this appliance at any time.
- Please make this information available to the person responsible for installing the appliance as it could reduce your installation costs.
- In order to avoid a hazard, this appliance must be installed according to these instructions for installation.
- This appliance is to be properly installed and earthed only by a suitably qualified person.
- This appliance should be connected to a circuit which incorporates an isolating switch providing full disconnection from the power supply.
- Failure to install the appliance correctly could invalidate any warranty or liability claims.

- This appliance can be used by children aged from 8 years and above and persons with reduced physical, sensory or mental capabilities or lack of experience and knowledge if they have been given supervision or instruction concerning use of the appliance in a safe way and understand the hazards involved.
- Children shall not play with the appliance. Cleaning and user maintenance shall not be made by children without supervision.
- If the supply cord is damaged, it must be replaced by the manufacturer, its service agent or similarly qualified persons in order to avoid a hazard.
- Warning: If the surface is cracked, switch off the appliance to avoid the possibility of electric shock, for hob surfaces of glass-ceramic or similar material which protect live parts
- Metallic objects such as knives, forks, spoons and lids should not be placed on the hob surface since they can get hot
- A steam cleaner is not to be used.
- Do not use a steam cleaner to clean your cooktop.
- The appliance is not intended to be operated by means of an external timer or separate remote-control system.
- WARNING: Danger of fire: do not store items on the cooking surfaces.
- The cooking process has to be supervised. A short term cooking process has to be supervised continuously.
- WARNING: Unattended cooking on a hob with fat or oil can be dangerous and may result in fire. NEVER try to extinguish a fire with water, but switch off the appliance and then cover flame e.g. with a lid or a fire blanket.

1.3 Operation and maintenance

1.3.1 Electrical Shock Hazard

- Do not cook on a broken or cracked cooktop. If the cooktop surface should break or crack, switch the appliance off immediately at the mains power supply (wall switch) and contact a qualified technician.
- Switch the cooktop off at the wall before cleaning or maintenance.
- Failure to follow this advice may result in electrical shock or death.

1.3.2 Health Hazard

- This appliance complies with electromagnetic safety standards.
- However, persons with cardiac pacemakers or other electrical implants (such as insulin pumps) must consult with their doctor or

implant manufacturer before using this appliance to make sure that their implants will not be affected by the electromagnetic field.

- Failure to follow this advice may result in death.

1.3.3 Hot Surface Hazard

- During use, accessible parts of this appliance will become hot enough to cause burns.
- Do not let your body, clothing or any item other than suitable cookware contact the Induction glass until the surface is cool.
- Keep children away.
- Handles of saucepans may be hot to touch. Check saucepan handles do not overhang other cooking zones that are on. Keep handles out of reach of children.
- Failure to follow this advice could result in burns and scalds.

1.3.4 Cut Hazard

- The razor-sharp blade of a cooktop scraper is exposed when the safety cover is retracted. Use with extreme care and always store safely and out of reach of children.
- Failure to use caution could result in injury or cuts.

1.3.5 Important safety instructions

- Never leave the appliance unattended when in use. Boilover causes smoking and greasy spillovers that may ignite.
- Never use your appliance as a work or storage surface.
- Never leave any objects or utensils on the appliance.
- Do not place or leave any magnetisable objects (e.g. credit cards, memory cards) or electronic devices (e.g. computers, MP3 players) near the appliance, as they may be affected by its electromagnetic field.
- Never use your appliance for warming or heating the room.
- After use, always turn off the cooking zones and the cooktop as described in this manual (i.e. by using the touch controls). Do not rely on the pan detection feature to turn off the cooking zones when you remove the pans.
- Do not allow children to play with the appliance or sit, stand, or climb on it.
- Do not store items of interest to children in cabinets above the appliance. Children climbing on the cooktop could be seriously injured.
- Do not leave children alone or unattended in the area where the appliance is in use.
- Children or persons with a disability which limits their ability to use

the appliance should have a responsible and competent person to instruct them in its use. The instructor should be satisfied that they can use the appliance without danger to themselves or their surroundings.

- Do not repair or replace any part of the appliance unless specifically recommended in the manual. All other servicing should be done by a qualified technician.
- Do not place or drop heavy objects on your cooktop.
- Do not stand on your cooktop.
- Do not use pans with jagged edges or drag pans across the Induction glass surface as this can scratch the glass.
- Do not use scourers or any other harsh abrasive cleaning agents to clean your cooktop, as these can scratch the Induction glass.
- This appliance is intended to be used in household and similar applications such as: -staff kitchen areas in shops, offices and other working environments; -farm houses; -by clients in hotels, motels and other residential type environments; -bed and breakfast type environments.
- **WARNING:** The appliance and its accessible parts become hot during use.
- Care should be taken to avoid touching heating elements.
- Children less than 8 years of age shall be kept away unless continuously supervised.

Congratulations

on the purchase of your new Induction Hob.
We recommend that you spend some time to read this Instruction / Installation Manual in order to fully understand how to install correctly and operate it.

For installation, please read the installation section.

Read all the safety instructions carefully before use and keep this Instruction / Installation Manual for future reference.

2. Product Induction

2.1 Top View

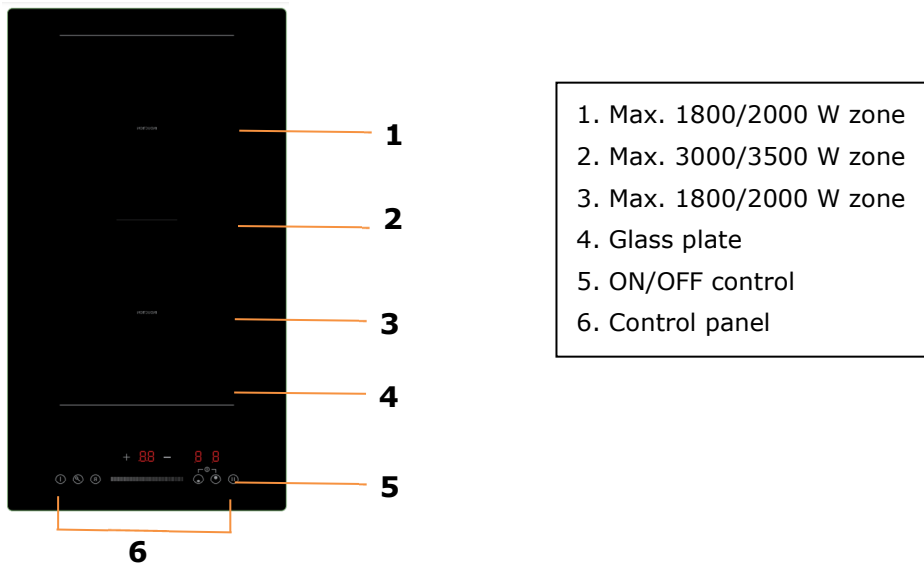

2.2 Control Panel

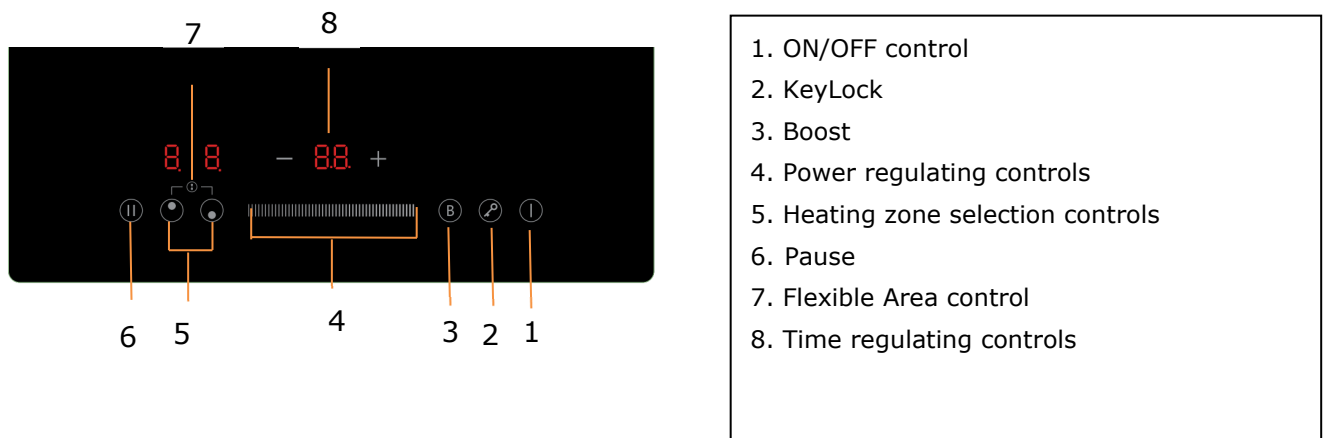

2.3 Working Theory

Induction cooking is a safe, advanced, efficient, and economical cooking technology. It works by electromagnetic vibrations generating heat directly in the pan, rather than indirectly through heating the glass surface. The glass becomes hot only because the pan eventually warms it up.

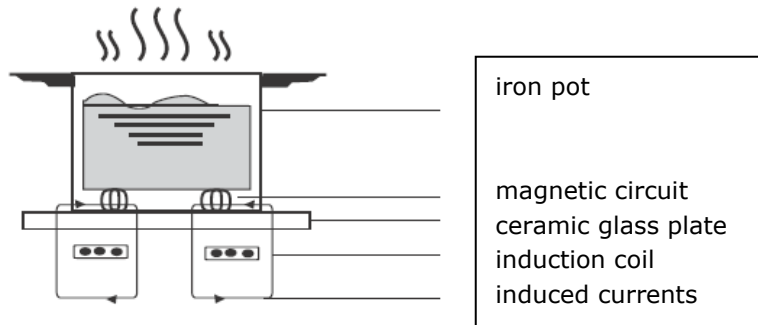

2.4 Before using your New Induction Hob

- Read this guide, taking special note of the 'Safety Warnings' section.
- Remove any protective film that may still be on your Induction hob.

2.5 Technical Specification

Cooking Zones	2 Zones
Supply Voltage	220-240V~ 50Hz or 60Hz
Installed Electric Power	3500W
Product Size LxWxH(mm)	288X520X59.5
Building-in Dimensions AxB (mm)	268X500

3. Operation of Product

3.1 Touch Controls

- The controls respond to touch, so you don't need to apply any pressure.
- Use the ball of your finger, not its tip.
- You will hear a beep each time a touch is registered.
- Make sure the controls are always clean, dry, and that there is no object (e.g. a utensil or a cloth) covering them. Even a thin film of water may make the controls difficult to operate.

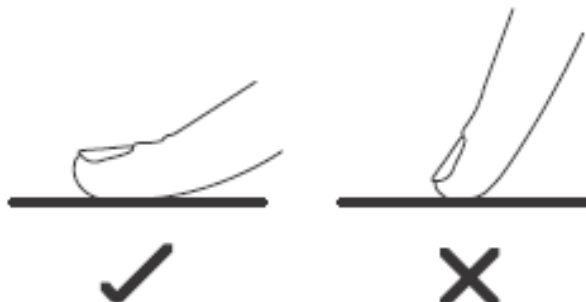

3.2 Choosing the right Cookware



- Only use cookware with a base suitable for induction cooking.
Look for the induction symbol on the packaging or on the bottom of the pan.

- You can check whether your cookware is suitable by carrying out a magnet test.
Move a magnet towards the base of the pan. If it is attracted, the pan is suitable for induction.
- If you do not have a magnet:
 1. Put some water in the pan you want to check.
 2. If  does not flash in the display and the water is heating, the pan is suitable.
- Cookware made from the following materials is not suitable: pure stainless steel, aluminium or copper without a magnetic base, glass, wood, porcelain, ceramic, and earthenware.
- Some pots and pans on the market are not suitable for induction cooking, Because they have only a part of the bottom in ferromagnetic material with parts in another material .These areas may heat up at different levels or with lower power. In certain cases, where the bottom is made mainly of non-ferromagnetic materials,the hob might not recognise the pan and therefore not switch on the cooking zone.

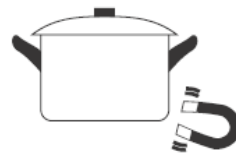

Do not use cookware with jagged edges or a curved base.



Make sure that the base of your pan is smooth, sits flat against the glass, and is the same size as the cooking zone. Use pans whose diameter is as large as the graphic of the zone selected. Using a pot a slightly wider energy will be used at its maximum efficiency. If you use smaller pot efficiency could be less than expected. Always centre your pan on the cooking zone.

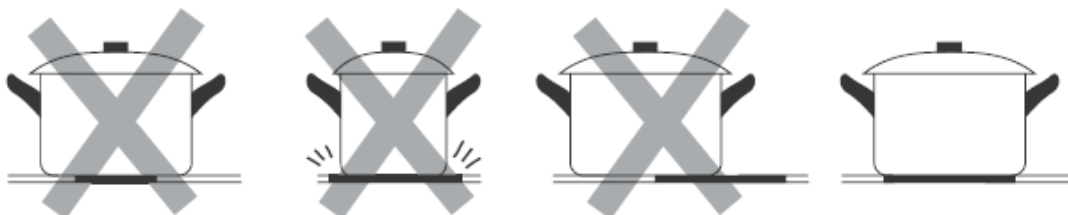

Always lift pans off the Induction hob – do not slide, or they may scratch the glass.

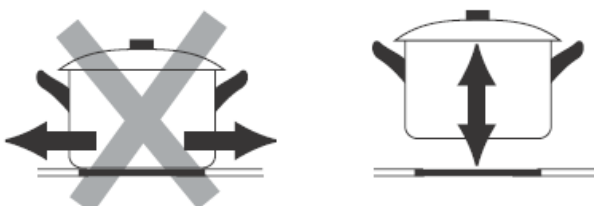

The cooking zones are, up to a limit, automatically adapted to the diameter of the pan. However the bottom of this pan must have a minimum of diameter according to the corresponding cooking zone. To obtain the best efficiency of your hob, please place the pan in the centre of the cooking zone.

Cooking zone	The base diameter of induction cookware	
	Minimum (mm)	Maximum (mm)
180mm	140	180
180mm	140	180

3.3 How to use

3.3.1 Start cooking

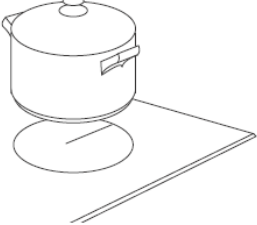
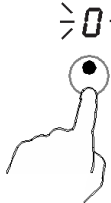
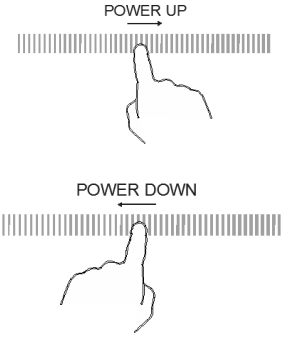
<p>Touch the ON/OFF control for a while. After power on, the buzzer beeps once, all displays show “—” or “— —”, indicating that the induction hob has entered the state of standby mode.</p>	
<p>Place a suitable pan on the cooking zone that you wish to use.</p> <ul style="list-style-type: none"> • Make sure the bottom of the pan and the surface of the cooking zone are clean and dry. 	
<p>Touching the heating zone selection control, and the indicator next to the key will flash</p>	
<p>Select a heat setting by touching the Slide control.</p> <ul style="list-style-type: none"> • If you don't choose a heat setting within 1 minute, the Induction hob will automatically switch off. You will need to start again at step 1. • You can modify the heat setting at any time during cooking. 	

If the display flashes alternately with the heat setting



This means that:

- you have not placed a pan on the correct cooking zone or,
- the pan you're using is not suitable for induction cooking or,
- the pan is too small or not properly centered on the cooking zone.

No heating takes place unless there is a suitable pan on the cooking zone.

The display will automatically turn off after 2 minutes if no suitable pan is placed on it.

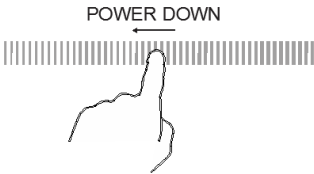
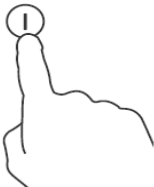
3.3.2 Finish cooking

<p>Touching the heating zone selection control that you wish to switch off</p>	
<p>Turn the cooking zone off by scrolling down to "0". Make sure the display shows "0".</p>	
<p>Turn the whole cooktop off by touching the ON/OFF control.</p>	
<p>Beware of hot surfaces H will show which cooking zone is hot to touch. It will disappear when the surface has cooled down to a safe temperature. It can also be used as an energy saving function if you want to heat further pans, use the hotplate that is still hot.</p>	

3.3.3 FLEXIBLE AREA

- This area can be used as a single zone or as two different zones, accordingly to the cooking needs anytime.
- Free area is made of two independent inductors that can be controlled separately.

As big zone

1. To activate the free area as a single big zone, Touching the Flexible Area control .

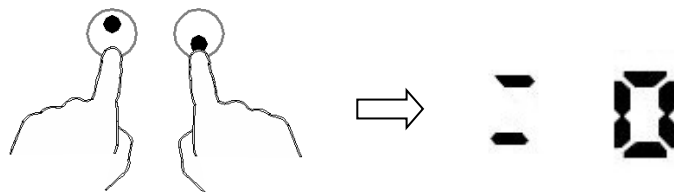

2. As a big zone, we suggest the used as the follow:

Cookware: 250mm or 280mm diameter cookware (Square or Oval cookware are acceptable)

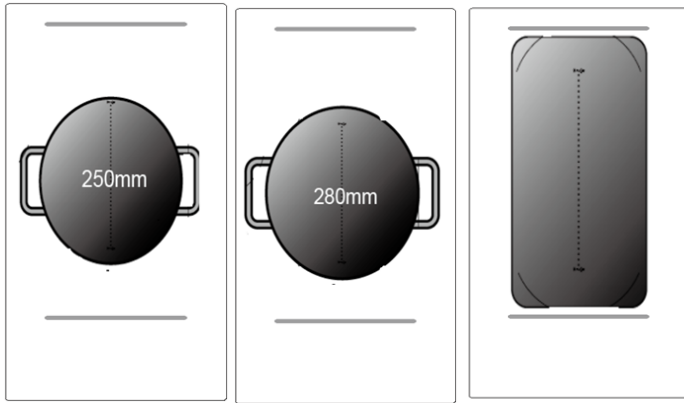

We don't recommend other operations except for above mentioned three operations because it might effect the heating of appliance

As two independent zones

To use the flexible area as two different zones, you can have two choices of heating.

(a) Put a pan on the right up side or the right down side of the flexible zone.

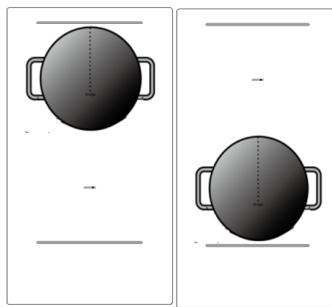

(b) Put two pans on both sides of the flexible zone.

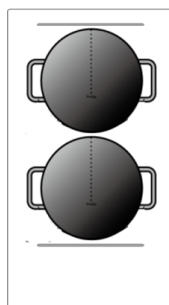



Notice: Make sure the pan is bigger than 12cm.

3.3.4 Locking the Controls

- You can lock the controls to prevent unintended use (for example children accidentally turning the cooking zones on).
- When the controls are locked, all the controls except the ON/OFF control are disabled.

To lock the controls	
Touch the lock control	The timer indicator will show "Lo"
To unlock the controls	
Touch and hold the lock control for a while.	



When the hob is in the lock mode, all the controls are disabled except the ON/OFF , you can always turn the induction hob off with the ON/OFF  control in an emergency, but you shall unlock the hob first in the next operation.





3.3.5 Timer control

You can use the timer in two different ways:



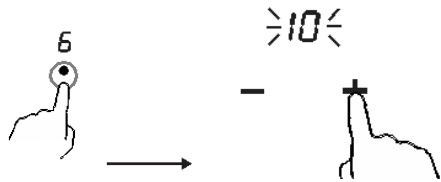
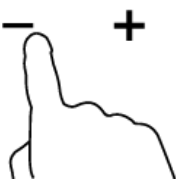
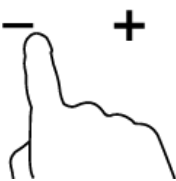

- You can use it as a minute minder. In this case, the timer will not turn any cooking zone off when the set time is up.
- You can set it to turn one or more cooking zones off after the set time is up. The timer of maximum is 99 min.

a) Using the Timer as a Minute Minder

If you are not selecting any cooking zone

Make sure the cooktop is turned on.	
Touch the controls of the timer. The minder indicator will start flashing and "10" will show in the timer display.	
Set the time by touching the "-" or "+" control of the timer Hint: Touch the "-" or "+" control of the timer to decrease or increase by 1 minute once. Touch and hold the "-" or "+" control of the timer to decrease or increase by 10 minutes.	
Touching the "-" and "+" together, the timer is cancelled, and the "00" will show in the minute display.	
When the time is set, it will begin to count down immediately. The display will show the remaining time and the timer indicator will flash for 5 seconds.	
Buzzer will beep for 30 seconds and the timer indicator shows "--" when the setting time finished.	

b) Setting the timer to turn one cooking zone off



Set one zone	
Touching the heating zone selection control that you want to set the timer for.	
Set the time by touching the "-" or "+" control of the timer Hint: Touch the "-" or "+" control of the timer once will decrease or increase by 1 minute. Touch and hold the "-" or "+" control of the timer will decrease or increase by 10 minutes.	
Touching the "-" and "+" together, the timer is cancelled, and the "00" will show in the minute display.	
When the time is set, it will begin to count down immediately. The display will show the remaining time and the timer indicator flash for 5 seconds. NOTE: The red dot next to power level indicator will illuminate indicating that zone is selected.	
When cooking timer expires, the corresponding cooking zone will be switch off automatically.	



Other cooking zone will keep operating if they are turned on previously.

3.3.6 Using the Boost function

Activate the boost function	
Touching the heating zone slider control	

Touching the Boost control. Make sure the display shows "P".	
Cancel the Boost function	
Touching the heating zone slider control that you wish to cancel the boost function.	
Turn the cooking zone off by touching the Boost control. Make sure the display shows "0".	

- The function can work in any cooking zone.
- The cooking zone returns to its original setting after 5 minutes.
- If the original heat setting equals 0, it will return to 9 after 5 minutes.

3.3.7 Default working times

Auto shut down is a safety protection function for your induction hob. It shut down automatically if ever you forget to turn off your cooking. The default working times for various power levels are shown in the below table:

Power level	1	2	3	4	5	6	7	8	9
Default working timer (hour)	8	8	8	4	4	4	2	2	2

When the pot is removed, the induction hob can stop heating immediately and the hob automatically switch off after 2 minutes.



People with a heart pace maker should consult with their doctor before using this unit.

4. Cooking Guidelines



Take care when frying as the oil and fat heat up very quickly, particularly if you're using PowerBoost. At extremely high temperatures oil and fat will ignite spontaneously and this presents a serious fire risk.

4.1 Cooking Tips

- When food comes to the boil, reduce the temperature setting.
- Using a lid will reduce cooking times and save energy by retaining the heat.
- Minimize the amount of liquid or fat to reduce cooking times.
- Start cooking on a high setting and reduce the setting when the food has heated through.

4.1.1 Simmering, cooking rice

- Simmering occurs below boiling point, at around 85°C, when bubbles are just rising occasionally to the surface of the cooking liquid. It is the key to delicious soups and tender stews because the flavours develop without overcooking the food. You should also cook egg-based and flour thickened sauces below boiling point.
- Some tasks, including cooking rice by the absorption method, may require a setting higher than the lowest setting to ensure the food is cooked properly in the time recommended.

4.1.2 Searing steak

To cook juicy flavorsome steaks:

1. Stand the meat at room temperature for about 20 minutes before cooking.
2. Heat up a heavy-based frying pan.
3. Brush both sides of the steak with oil. Drizzle a small amount of oil into the hot pan and then lower the meat onto the hot pan.
4. Turn the steak only once during cooking. The exact cooking time will depend on the thickness of the steak and how cooked you want it. Times may vary from about 2 – 8 minutes per side. Press the steak to gauge how cooked it is – the firmer it feels the more 'well done' it will be.
5. Leave the steak to rest on a warm plate for a few minutes to allow it to relax and become tender before serving.

4.1.3 For stir-frying

1. Choose an induction compatible flat-based wok or a large frying pan.
2. Have all the ingredients and equipment ready. Stir-frying should be quick. If cooking large quantities, cook the food in several smaller batches.
3. Preheat the pan briefly and add two tablespoons of oil.
4. Cook any meat first, put it aside and keep warm.
5. Stir-fry the vegetables. When they are hot but still crisp, turn the cooking zone to a lower setting, return the meat to the pan and add your sauce.
6. Stir the ingredients gently to make sure they are heated through.
7. Serve immediately.

4.2 Detection of Small Articles

When an unsuitable size or non-magnetic pan (e.g. aluminium), or some other small item (e.g. knife, fork, key) has been left on the hob, the hob automatically go on to standby in 1 minute. The fan will keep cooking down the induction hob for a further 1 minute.

4.3 Automatic OFF mode

If there is no any operation after switch on the hob, the hob will reach automatically the off mode after 1 minute and the power is 0.5W in off mode.

5. Heat Settings

The settings below are guidelines only. The exact setting will depend on several factors, including your cookware and the amount you are cooking. Experiment with the induction hob to find the settings that best suit you.

Heat setting	Suitability
1 - 2	<ul style="list-style-type: none"> • delicate warming for small amounts of food • melting chocolate, butter, and foods that burn quickly • gentle simmering • slow warming
3 - 4	<ul style="list-style-type: none"> • reheating • rapid simmering • cooking rice
5 - 6	<ul style="list-style-type: none"> • pancakes
7 - 8	<ul style="list-style-type: none"> • sautéing • cooking pasta
9	<ul style="list-style-type: none"> • stir-frying • searing • bringing soup to the boil • boiling water

6. Care and Cleaning

What?	How?	Important!
Everyday soiling on glass (fingerprints, marks, stains left by food or non-sugary spillovers on the glass)	<ol style="list-style-type: none"> 1. Switch the power to the cooktop off. 2. Apply a cooktop cleaner while the glass is still warm (but not hot!) 3. Rinse and wipe dry with a clean cloth or paper towel. 4. Switch the power to the cooktop back on. 	<ul style="list-style-type: none"> • When the power to the cooktop is switched off, there will be no 'hot surface' indication but the cooking zone may still be hot! Take extreme care. • Heavy-duty scourers, some nylon scourers and harsh/abrasive cleaning agents may scratch the glass. Always read the label to check if your cleaner or scourer is suitable. • Never leave cleaning residue on the cooktop: the glass may become stained.
Boil overs, melts, and hot sugary spills on the glass	<p>Remove these immediately with a fish slice, palette knife or razor blade scraper suitable for Induction glass cooktops, but beware of hot cooking zone surfaces:</p> <ol style="list-style-type: none"> 1. Switch the power to the cooktop off at the wall. 2. Hold the blade or utensil at a 30° angle and scrape the soiling or spill to a cool area of the cooktop. 3. Clean the soiling or spill up with a dish cloth or paper towel. 4. Follow steps 2 to 4 for 'Everyday soiling on glass' above. 	<ul style="list-style-type: none"> • Remove stains left by melts and sugary food or spillovers as soon as possible. If left to cool on the glass, they may be difficult to remove or even permanently damage the glass surface. • Cut hazard: when the safety cover is retracted, the blade in a scraper is razor-sharp. Use with extreme care and always store safely and out of reach of children.

Spillovers on the touch controls	<ol style="list-style-type: none"> 1. Switch the power to the cooktop off. 2. Soak up the spill 3. Wipe the touch control area with a clean damp sponge or cloth. 4. Wipe the area completely dry with a paper towel. 5. Switch the power to the cooktop back on. 	<ul style="list-style-type: none"> • The cooktop may beep and turn itself off, and the touch controls may not function while there is liquid on them. Make sure you wipe the touch control area dry before turning the cooktop back on.
----------------------------------	--	--

7. Hints and Tips

Problem	Possible causes	What to do
The induction hob cannot be turned on.	No power.	Make sure the induction hob is connected to the power supply and that it is switched on. Check whether there is a power outage in your home or area. If you've checked everything and the problem persists, call a qualified technician.
The touch controls are unresponsive.	The controls are locked.	Unlock the controls. See section 'Using your induction cooktop' for instructions.
The touch controls are difficult to operate.	There may be a slight film of water over the controls or you may be using the tip of your finger when touching the controls.	Make sure the touch control area is dry and use the ball of your finger when touching the controls.
The glass is being scratched.	<p>Rough-edged cookware.</p> <p>Unsuitable, abrasive scourer or cleaning products being used.</p>	<p>Use cookware with flat and smooth bases. See 'Choosing the right cookware'.</p> <p>See 'Care and cleaning'.</p>
Some pans make crackling or clicking noises.	This may be caused by the construction of your cookware (layers of different metals vibrating differently).	This is normal for cookware and does not indicate a fault.
The induction hob makes a low humming noise when used on a high heat setting.	This is caused by the technology of induction cooking.	This is normal, but the noise should quieten down or disappear completely when you decrease the heat setting.
Fan noise coming from the induction hob.	A cooling fan built into your induction hob has come on to prevent the electronics from overheating. It may continue to run even after you've turned the induction hob off.	This is normal and needs no action. Do not switch the power to the induction hob off at the wall while the fan is running.

Pans do not become hot and appears in the display.	<p>The induction hob cannot detect the pan because it is not suitable for induction cooking.</p> <p>The induction hob cannot detect the pan because it is too small for the cooking zone or not properly centred on it.</p>	<p>Use cookware suitable for induction cooking. See section 'Choosing the right cookware'.</p> <p>Centre the pan and make sure that its base matches the size of the cooking zone.</p>
The induction hob or a cooking zone has turned itself off unexpectedly, a tone sounds and an error code is displayed (typically alternating with one or two digits in the cooking timer display).	Technical fault.	Please note down the error letters and numbers, switch the power to the induction hob off at the wall, and contact a qualified technician.

8. Failure Display and Inspection

The induction hob is equipped with a self diagnostic function. With this test the technician is able to check the function of several components without disassembling or dismantling the hob from the working surface.

Troubleshooting

1) Failure code occur during customer using & Solution;

Failure code	Problem	Solution
No Auto-Recovery		
E1	Ceramic plate temperature sensor failure-- open circuit.	Check the connection or replace the ceramic plate temperature sensor.
E2	Ceramic plate temperature sensor failure- - short circuit.	
E7	Ceramic plate temperature sensor failure	
C1	High temperature of ceramic plate sensor.	<p>Wait for the temperature of ceramic plate return to normal.</p> <p>Touch "ON/OFF" button to restart unit.</p>
E3	Temperature sensor of the IGBT failure --open circuit.	Replace the power board.
E4	Temperature sensor of the IGBT failure --short circuit	
C2	High temperature of IGBT.	<p>Wait for the temperature of IGBT return to normal.</p> <p>Touch "ON/OFF" button to restart unit.</p> <p>Check whether the fan runs smoothly; if not , replace the fan.</p>
EL	Supply voltage is below the rated voltage.	<p>Please inspect whether power supply is normal.</p> <p>Power on after the power supply is normal.</p>
EH	Supply voltage is above the rated voltage.	

EU	Communication error.	Reinsert the connection between the display board and the power board. Replace the power board or the display board.
----	----------------------	---

2) Specific Failure & Solution

Failure	Problem	Solution A	Solution B
The LED does not come on when unit is plugged in.	No power supplied.	Check to see if plug is secured tightly in outlet and that outlet is working.	
	The accessorial power board and the display board connected failure.	Check the connection.	
	The accessorial power board is damaged.	Replace the accessorial power board.	
	The display board is damaged.	Replace the display board.	
Some buttons can't work, or the LED display is not normal.	The display board is damaged.	Replace the display board.	
The Cooking Mode Indicator comes on, but heating does not start.	High temperature of the hob.	Ambient temperature may be too high. Air Intake or Air Vent may be blocked.	
	There is something wrong with the fan.	Check whether the fan runs smoothly; if not , replace the fan.	
	The power board is damaged.	Replace the power board.	
Heating stops suddenly during operation and the display flashes " <u>u</u> ".	Pan Type is wrong.	Use the proper pot (refer to the instruction manual.)	Pan detection circuit is damaged, replace the power board.
	Pot diameter is too small.		
	Cooker has overheated;	Unit is overheated. Wait for temperature to return to normal. Push "ON/OFF" button to restart unit.	
Heating zones of the same side (Such as the first and the second zone) would display " <u>u</u> ".	The power board and the display board connected failure;	Check the connection.	
	The display board of communicate part is damaged.	Replace the display board.	
	The Main board is damaged.	Replace the power board.	
Fan motor sounds abnormal.	The fan motor is damaged.	Replace the fan.	

The above are the judgment and inspection of common failures.

Please do not disassemble the unit by yourself to avoid any dangers and damages to the induction hob.

9. Installation

9.1 Selection of installation equipment

Cut out the work surface according to the sizes shown in the drawing.

For the purpose of installation and use, a minimum of 50mm space shall be preserved around the hole.

Be sure the thickness of the work surface is at least 30mm. Please select heat-resistant and insulated work surface material (Wood and similar fibrous or hygroscopic material shall not be used as work surface material unless impregnated) to avoid the electrical shock and larger deformation caused by the heat radiation from the hotplate. As shown below:



Note: The safety distance between the sides of the hob and the inner surfaces of the worktop s should be at least 3mm.

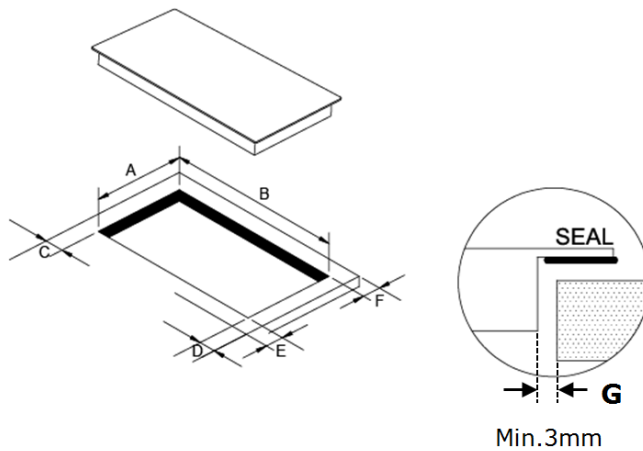

A(mm)	B(mm)	C(mm)	D(mm)	E(mm)	F(mm)	G
268 ⁺⁴ -0	500 ⁺⁴ -0	50min.	50 min.	50 min.	50 min.	3mm min.

Under any circumstances, make sure the Induction cooker hob is well ventilated and the air inlet and outlet are not blocked. Ensure the Induction cooker hob is in good work state. As shown below



Note: The safety distance between the hotplate and the cupboard above the hotplate should be at least 760mm.

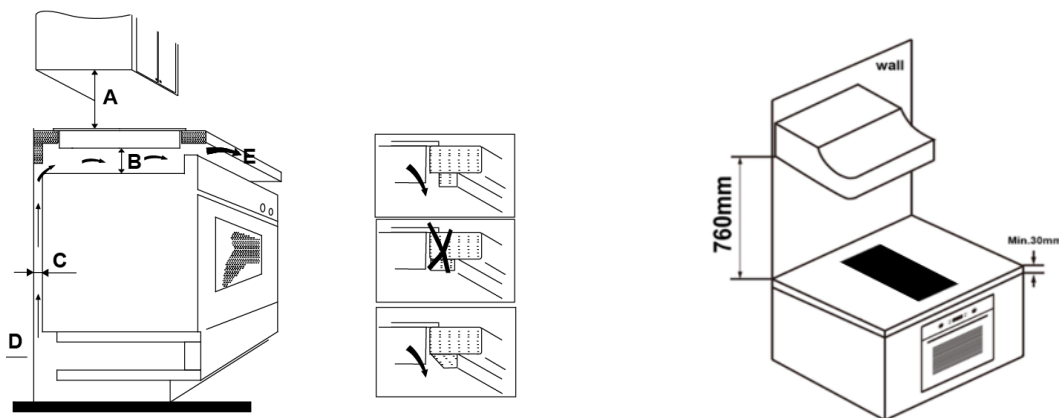

A(mm)	B(mm)	C(mm)	D	E
760	50 min.	20 min.	Air intake	Air exit 5 mm

WARNING: Ensuring Adequate Ventilation

Make sure the induction cooker hob is well ventilated and that air inlet and outlet are not blocked. In order to avoid accidental touch with the overheating bottom of the hob, or getting unexpected electric shock during working, it is necessary to put a wooden insert, fixed by screws, at a minimum distance of 50mm from the bottom of the hob. Follow the requirements below.

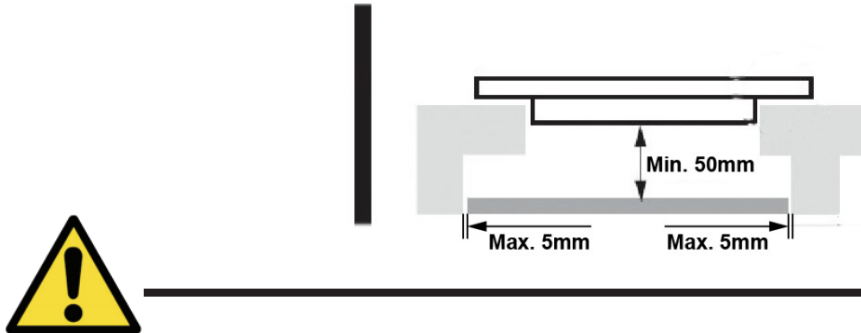

There are ventilation holes around outside of the hob. YOU MUST ensure these holes are not blocked by the worktop when you put the hob into position.



- Be aware that the glue that join the plastic or wooden material to the furniture, has to resist to temperature not below 150°C, to avoid the unstuck of the paneling.
- The rear wall, adjacent and surrounding surfaces must therefore be able to withstand an temperature of 90°C.

9.2 Before installing the hob, make sure that

- The work surface is square and level, and no structural members interfere with space requirements.
- The work surface is made of a heat-resistant and insulated material.
- If the hob is installed above an oven, the oven has a built-in cooling fan.
- The installation will comply with all clearance requirements and applicable standards and regulations.
- A suitable isolating switch providing full disconnection from the mains power supply is incorporated in the permanent wiring, mounted and positioned to comply with the local wiring rules and regulations.

The isolating switch must be of an approved type and provide a 3 mm air gap contact separation in all poles (or in all active [phase] conductors if the local wiring rules allow for this variation of the requirements).

- The isolating switch will be easily accessible to the customer with the hob installed.
- You consult local building authorities and by-laws if in doubt regarding installation.
- You use heat-resistant and easy-to-clean finishes (such as ceramic tiles) for the wall surfaces surrounding the hob.

9.3 After installing the hob, make sure that

- The power supply cable is not accessible through cupboard doors or drawers.
- There is adequate flow of fresh air from outside the cabinetry to the base of the hob.
- If the hob is installed above a drawer or cupboard space, a thermal protection barrier is installed below the base of

the hob.

- The isolating switch is easily accessible by the customer.

9.4 Before locating the fixing brackets

The unit should be placed on a stable, smooth surface (use the packaging). Do not apply force onto the controls protruding from the hob.

9.5 Adjusting the bracket position

Fix the hob on the work surface by screw 4 brackets on the bottom of hob(see picture) after installation. Adjust the bracket position to suit for different table top thickness.

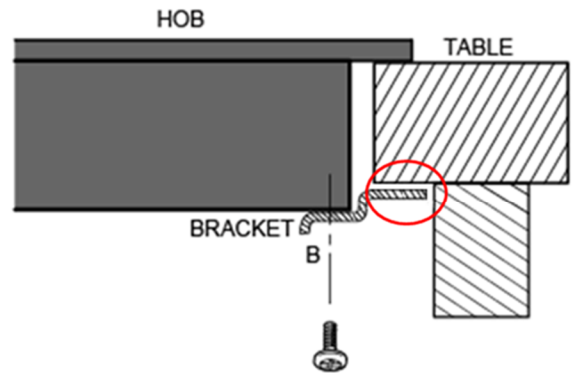
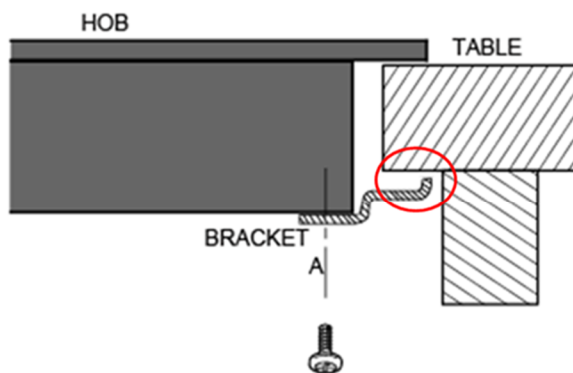
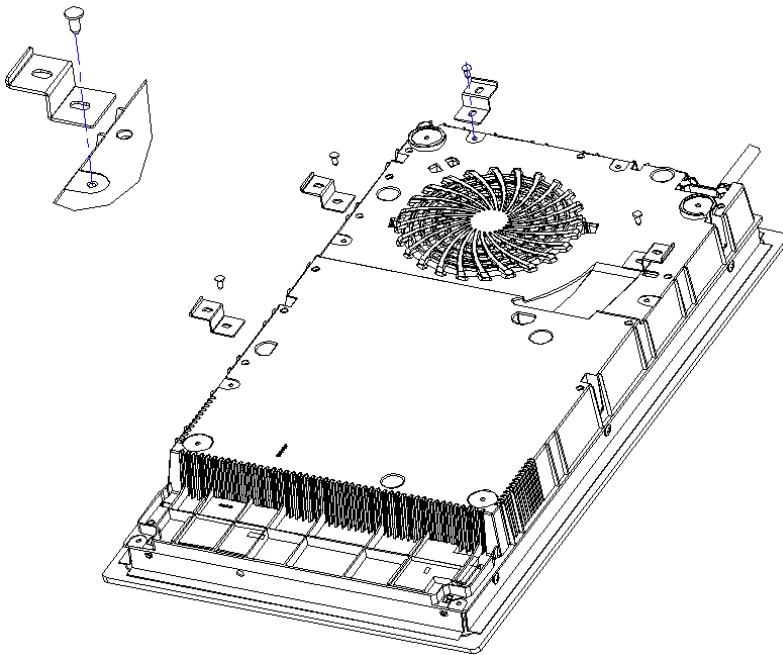

Under any circumstances, the brackets cannot touch with the inner surfaces of the worktop after installation (see picture).

9.6 Cautions

1. The induction hotplate must be installed by qualified personnel or technicians. We have professionals at your service. Please never conduct the operation by yourself.
2. The hob will not be installed directly above a dishwasher, fridge, freezer, washing machine or clothes dryer, as the humidity may damage the hob electronics
3. The induction hotplate shall be installed such that better heat radiation can be ensured to enhance its reliability.
4. The wall and induced heating zone above the table surface shall withstand heat.
5. To avoid any damage, the sandwich layer and adhesive must be resistant to heat.
6. A steam cleaner is not to be used.

9.7 Connecting the hob to the mains power supply



This hob must be connected to the mains power supply only by a suitably qualified person. Before connecting the hob to the mains power supply, check that:

1. The domestic wiring system is suitable for the power drawn by the hob.
2. The voltage corresponds to the value given in the rating plate
3. The power supply cable sections can withstand the load specified on the rating plate.

To connect the hob to the mains power supply, do not use adapters, reducers, or branching devices, as they can cause overheating and fire.

The power supply cable must not touch any hot parts and must be positioned so that its temperature will not exceed 75°C at any point.



Check with an electrician whether the domestic wiring system is suitable without alterations. Any alterations must only be made by a qualified electrician.

The power supply should be connected in compliance with the relevant standard, or a single-pole circuit breaker. The method of connection is shown below.

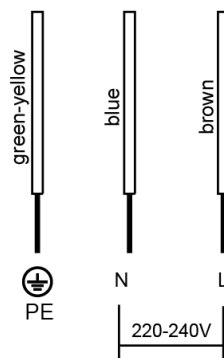

- If the cable is damaged or to be replaced, the operation must be carried out by the after-sale agent with dedicated tools to avoid any accidents.
- If the appliance is being connected directly to the mains an omnipolar circuit-breaker must be installed with a minimum opening of 3mm between contacts.
- The installer must ensure that the correct electrical connection has been made and that it is compliant with safety regulations.
- The cable must not be bent or compressed.
- The cable must be checked regularly and replaced by authorised technicians only.
- The yellow/green wire of the power supply cable must be connected to the earth of both power supply and appliance terminals.
- The manufacturer cannot be held responsible for any accidents resulting from the use of an appliance which is not connected to earth, or with faulty earth connection continuity.
- If the appliance has a socket outlet, it must be installed so that the socket outlet is accessible.



The bottom surface and the power cord of the hob are not accessible after installation.



DISPOSAL: Do not dispose this product as unsorted municipal waste. Collection of such waste separately for special treatment is necessary.

This appliance is labeled in compliance with European directive 2012/19/EU for Waste Electrical and Electronic Equipment (WEEE). By ensuring that this appliance is disposed of correctly, you will help prevent any possible damage to the environment and to human health, which might otherwise be caused if it were disposed of in the wrong way.

The symbol on the product indicates that it may not be treated as normal household waste. It should be taken to a collection point for the recycling of electrical and electronic goods.

This appliance requires specialist waste disposal. For further information regarding the treatment, recover and recycling of this product please contact your local council, your household waste disposal service, or the shop where you purchased it.

For more detailed information about treatment, recovery and recycling of this product, please contact your local city office, your household waste disposal service or the shop where you purchased the product.